

**Instrumentation & Software for Animal Research Professionals**

# Animal Sciences

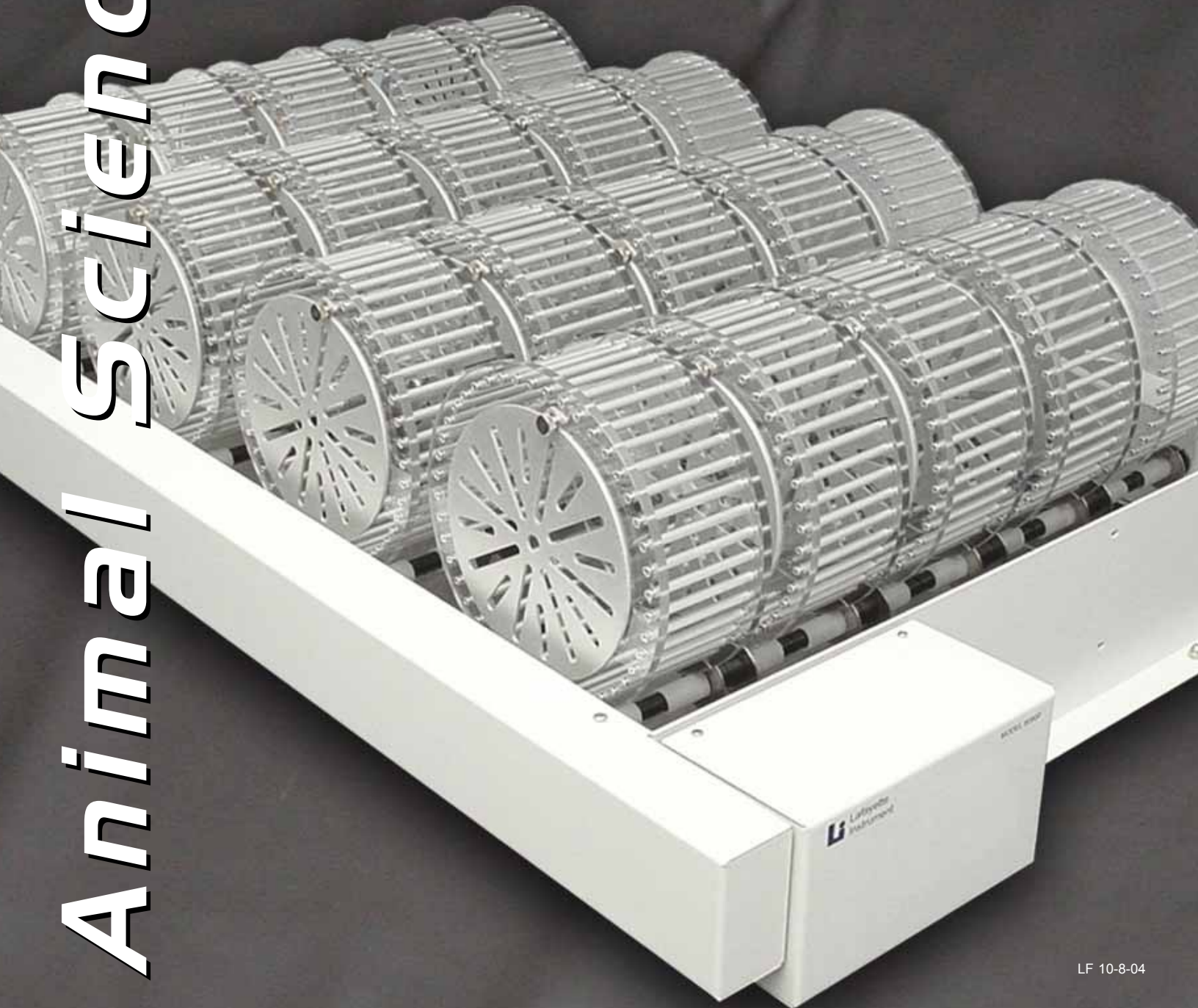

# Table of Contents

<b>Operant Systems</b>	3
<b>Activity &amp; Exercise Systems</b>	18
<b>PhotoBeam Activity</b>	28
<b>Anti-Depression/Anxiety</b>	35
<b>Learning &amp; Memory Systems</b>	43
<b>Startle Systems</b>	48
<b>Feeding Analysis</b>	52
<b>Motility</b>	54
<b>Monkey CANTAB</b>	58
<b>Ordering Information</b>	63



# Operant Systems

- *ABET*
- *Operant Chambers*
- *Learning System*
- *Chamber Accessories*
- *Sound Attenuation Cubicles*
- *9-Hole Boxes for Rat & Mouse*



# *Animal Behavior Environment Test System*

The Animal Behavior Environment Test System (ABET) is a fully integrated, Microsoft Windows™ - based program that allows for flexible computerized control and monitoring of up to 16 environments. Compatible with virtually any animal behavior equipment, the ABET software program provides a user-friendly, point-and-click programming method to create an unlimited number of schedules. ABET eliminates your need to learn computer programming to operate the system. All of the system options are chosen through a series of pull-down windows, buttons, and check boxes.

Hardware assignment has also been made quick and simple. All the user needs to know is the interface number and the line the device is wired into on the input/output module. Input and output devices are referred to by their actual name, such as "press bar" and "pellet dispenser". Testing input and output devices for proper functionality, prior to running schedules, is easy with the use of an on-screen diagnostic program.

Through the use of Boolean algebraic equations, schedules become logical representations of the experiment protocol. This makes the system flexible enough for even the most complex schedules, but easy enough to learn in a matter of minutes.

## **ABET Features:**

***With ABET, hardware address assignment is quick and easy.***

***Preprogrammed schedules can be used for immediate testing and can also be modified to meet your specific requirements.***

***Creating your own schedules from scratch is made easy with the use of Boolean algebraic equations.***

***The user can take advantage of simultaneous schedule flow, sequential schedule flow, or a combination of both.***

***Identical and/or different schedules can be run on up to 16 environments simultaneously.***

***Visual indicators are used to easily monitor each environment's schedule status.***

***Universal terminal block connections allow ABET to be used with animal hardware from most manufacturers.***

***Text-based, comma-delimited data makes importing results into any analysis software quick and easy.***







## ABET HARDWARE

### ABET Starter Kit Model 88500

**ABET Starter Interface**  
**ABET Interface Cable & Converter Box**  
**ABET Computer Interface Card**  
**Set of 6' 36-pin Centronic Cables (2)**  
**Mini I/O Module**  
**DB-25 Cable, 10'**  
**Power Supply, 28V DC**  
**Animal Behavior Environment Test System Software**

**Model 81401**  
**Model 81403**  
**Model 81404**  
**Model 81405-6**  
**Model 81409**  
**Model 81406-10**  
**Model 83619**  
**Model 89500**



### Optional Cables:

**Set of 25' 36-pin Centronic Cables Model 81405-25**

These cables may be used in place of the Model 81405-6 set of cables above to connect the starter interface to the converter box.

**10' DB-25 Cable Model 81406-10**  
**25' DB-25 Cable Model 81406-25**  
**50' DB-25 Cable Model 81406-50**

These cables connect interface to test chamber and may be used in addition to or as replacements for the Model 81406-10 cable above, and with the ABET Expander Components below. Connect multiple cables together as needed up to 100' maximum.

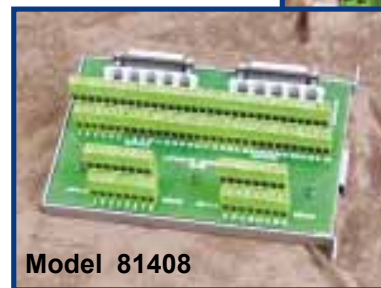

### ABET Expander Equipment

**ABET Expander Interface Model 81402**

The interface hardware allows the ABET software program to control the animal behavior equipment as desired. The Expander Interfaces connect to the Base Interface through a direct connection in a vertically stacked configuration. Up to 15 Expander Interfaces may be stacked, to create a complete system of 16 environments. Each interface provides up to 16 digital input lines and 32 digital output lines per environment.

**Full I/O Module Model 81408**  
**Mini I/O Module Model 81409**

The Full Module provides 16 input and 32 output lines through multilevel, screw clamp terminal blocks for easy connection of animal hardware. This module also includes 10 modular connections for control of up to 10 intensity modules. The Mini Module provides 8 input and 15 output lines. This module also includes 5 modular connections for control of up to 5 intensity modules. The modules can be mounted directly to the base of your animal equipment. Each modular connection uses 3 output lines.

### Technical Specifications

Maximum Number of Interfaces: 16  
 Maximum Number of Outputs per Interface: 32  
 Maximum Number of Inputs per Interface: 16  
 Maximum Number of Intensity Modules per Interface: 10  
 Maximum Supply Voltage: 35VDC  
 Minimum Supply Voltage: 22VDC  
 Quiescent Current per Interface: 40mA  
 Maximum Output Current per Interface: 2A  
 Maximum Current per Output: 0.5A  
 Maximum Output Line Voltage: 50VDC  
 Maximum Input Line Voltage: 50VDC  
 Maximum Length Between Computer and Interface Stack: 25'  
 Maximum Length Between Interface Stack and Environments: 100'  
 Power Connector: 2.1mm Center-Positive DC Jack  
 Operating System: Windows® 95/98/2000/XP  
 Timing Resolution: 1mS  
 Computer Requirements: Pentium Class  
 32MB RAM  
 20MB of Available Hard Disk Space  
 CD-ROM Drive  
 PCI Slot (ISA can be ordered if necessary)

## ABET HARDWARE (CONTINUED)

### Light Intensity Module Model 81407LM

This module provides control of the intensity of the Stimulus Lights Model 80221 in 7 discrete steps. It connects directly to the I/O Modules using a modular plug.

### Tone Intensity Module Model 81407TM

This module provides control of the intensity of the Sonalert Tone Model 80223 in 7 discrete steps. It connects directly to the I/O Modules using a modular plug.

### I/O Module Baseboard Model 81412

This 9"x9" plastic baseboard can be used to mount the I/O Modules when a chamber baseboard is not available.

### DB-25 to Cinch Jones Model 81411

This custom cable is designed for users who are interested in replacing their Operant Conditioning Console Model 81335A with an ABET system. It provides a direct connection from the interface to the standard Cinch Jones connector used with the cabling from the Operant Chamber.

### 28 Volt Power Supply Model 83619

This 2A power supply will operate 2 or more operant cages. Multiple power supplies can be connected to the interface stack as needed. Short circuit protection is provided by internal current foldback circuitry.

Dimensions: 12.75"x9.75"x5.5"

## ABET SOFTWARE

### Model 89500 Animal Behavior Environment Test System Software

The ABET software uses four basic windows - Environment Configuration, Schedule Configuration, Monitoring Configuration, and Run Schedule. This easy-to-use, no-programming-necessary, software system was designed with pull-down menus to make schedule configuration and hardware address setup a breeze.

### Environment Addressing

The environment configuration window provides the ability to assign specific hardware addresses to each individual hardware device. As the hardware devices and data lines are selected, the program automatically assigns a label to represent the specific device. The environment number that is selected is controlled by a pull-down list located within that window. A specific environment name may be assigned to any given environment. If a name is assigned, the environment will be referred to by that name in other program windows. If a name is not entered, the environment will be referred to by a number. To assign an input or output device address, a pull-down list is used to select the desired device label. Once the label is selected, simply click the check box next to the desired data line. A list of the address assignments is automatically created.

### Schedule Configuration

The schedule configuration window provides the ability to configure schedules through the use of Boolean algebraic created conditions. After each of the conditions is defined, the conditions are added to the schedule and a group number and sequence number are assigned to each condition. The group and sequence numbers define the order of evaluation for the conditions and provide the ability to determine the flow of the schedule. When the condition is considered true, the actions that are selected are then executed and the schedule continues on to the next condition as defined by the sequence number and group number.

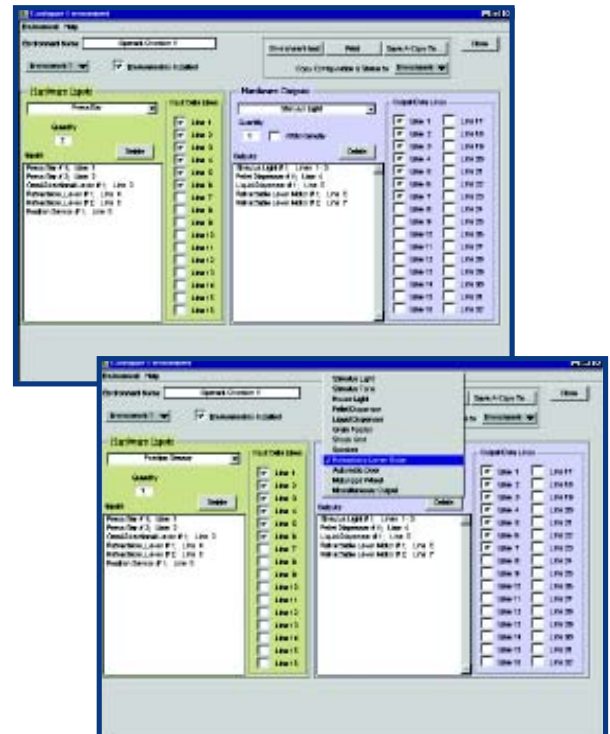



## ABET SOFTWARE

### Condition Control

The condition control window provides the ability to configure schedules with unlimited conditional statements and unlimited actions. These conditional statements create a Boolean algebraic equation. The conditions are created using the hardware labels that represent the particular hardware device. Group and sequence numbers are used to define the order of evaluation for the conditions and provide the ability to have simultaneous schedule flow, sequential schedule flow, or a combination of both. When the condition is considered true, the actions that are selected are then executed, and the schedule continues on to the next condition in sequence. The conditions follow the Boolean algebraic rules for evaluation. Each conditional statement is evaluated as either true or false. The logical operators that connect the statements then determine whether the entire condition is true or false. If a condition is evaluated as true, the actions for that condition will be executed. Each of these action statements consist of a control for the device, a selection of the device, and an ID number. An intensity adjustment is entered if intensity modules are used. You may save any created condition. When the condition is saved, the condition name is added to the list of conditions in the schedule window and may be used for future schedules.

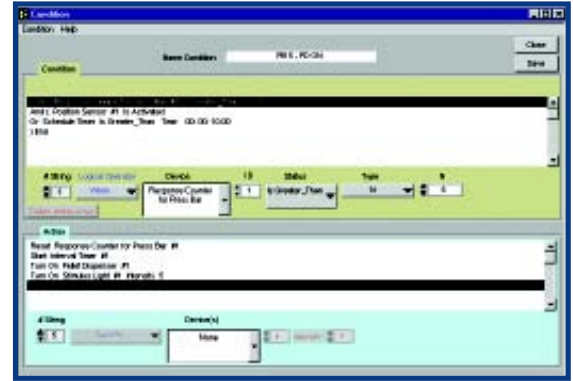

### Monitoring Configuration

The monitoring configuration window provides the ability to select the hardware devices, counters and timers to display during the execution of the schedule. The values that are displayed are for user feedback during the experiment to ensure that the schedule is proceeding as expected. When the schedule is running, monitoring windows will be opened to display the items selected from the monitoring configuration window. Changes to the selection of the devices to monitor can be updated on schedules that are running.



### Run Schedule Configuration

The run schedule window provides the ability to start a schedule in a selected environment. Schedules can be run for a specific length of time or number of trials before completion, or the schedule can run until it is manually stopped. While the schedule is running, a text-based time-stamped file is created to store the results of the schedule. Schedules can be started individually or stored as experiments for simultaneous starting on multiple environments. When the schedule is running, monitoring windows will be opened to display the items selected from the monitoring configuration window. The values that are displayed are for user feedback during the experiment to ensure that the schedule is proceeding as expected.

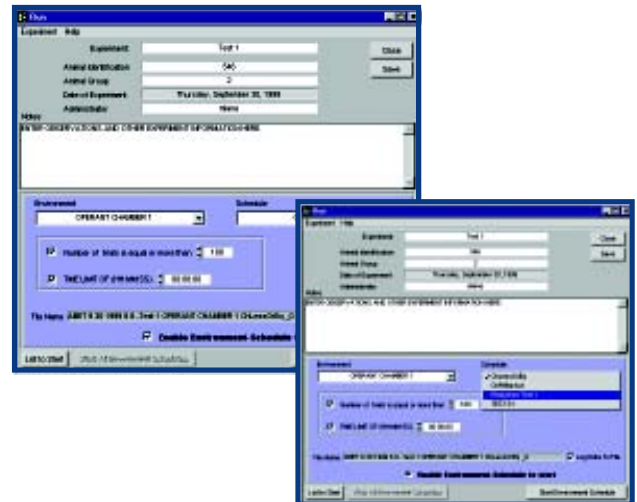

### Data Acquisition

The data file is a comma-delimited text file that can be imported into virtually any spreadsheet application for analysis. The data file first stores the header information entered in the run schedule window. This information includes the experiment name, animal identification, animal group, date of experiment, administrator, and notes about the experiment. It is then formatted into a table that separates all of the hardware devices of the environment and the internal counters and timers used in the schedule into columns. Each time a condition is evaluated as true, and the actions occur, the software records the time when they were executed, as well as the current state of the devices.



## OPERANT CHAMBERS

**Basic Operant Chamber (Rat)**

**Basic Operant Chamber (Mouse) (not shown)**

**Operant Chamber with Non-shock Floor, Rat or Mouse (not shown)**

**Model 80003**

**Model 80003M**

**Model 80003NS**

Built for long-lasting durability and easy cleaning, our front/top-loading operant chamber is constructed of .032" stainless steel and .25" polycarbonate. The base is made of high density polyethylene that is stain- and scent-resistant. This cage is prepunched to handle 4 press bars, 4 stimulus lights, a pellet dispenser and a liquid dispenser. The top will accommodate an omnidirectional lever, and the removable floor is made of shockable grid rods. The non-shock floor for Model 80003NS is made of stainless steel wire mesh. Side and top panels can be customized to satisfy your needs. Dimensions: 8.5"x8.5"x11"



**Model 80003  
w/ accessories**

**Pigeon Operant Chamber (not shown)**

**Pecking Key with 3-Color Display (not shown)**

**Standard Pecking Key (not shown)**

**Grainfeeder (not shown)**

**Model 80005**

**Model 80123**

**Model 80125**

**Model 80205**

Built to the same rugged standard as our Basic Operant Cage, the Pigeon Operant Chamber, is constructed of .032" stainless steel, and .25" clear polycarbonate. There are 23 stainless steel grid rods .1875" in diameter and are spaced .50" apart. The base is made of high density polyethylene that is stain- and scent-resistant. This cage can be equipped with 3 pecking keys and a grainfeeder. The optional 3-color pecking key can display red, green and white. Dimensions: 12"x12"x12.5"

## LEARNING SYSTEM

**Complete Learning System Model 84025**

The Lafayette Learning System is your complete system for teaching operant conditioning. This system includes a four-lever cage with shockable grid floor, two press bars, an omnidirectional lever, two stimulus lights, a pellet dispenser, and a liquid dispenser. Also included is the easy-to-use conditioning console complete with 13 preprogrammed schedules. Dimensions: Cage- 12"x12"x12.5" Conditioning Control - 12"x8"x7"



**Model 84025**

**Operant Conditioning Console Model 81335B**

The Operant Conditioning Console Model 81335B is a fully integrated animal learning control instrument used for laboratory studies. All schedules can be easily programmed and implemented in a variety of environments. Manual shaping activation and student participation is also provided.

The Operant Conditioning Console Model 81335B has the capability to be used with the following devices:

- Pellet Dispenser Model 80208
- Liquid Dispenser Model 80201
- Air Stimulus Model 80108
- 4 Press Bars Model 80110
- 4 Stimulus Lights Model 80221
- 4 Stimulus Tones Model 80223
- 4 Auxiliary Outputs



**Model 81335B**





## OPERANT CHAMBER ACCESSORIES

### Sure Drop Pellet Dispenser Model 80208

This new style of pellet dispenser no longer relies on meshing disks which were prone to jamming. By using a solenoid, the dispenser can deliver up to six, 45mg pellets a second. This pellet dispenser also features an optional tone, when dispensing, to aid in shaping. There is an external switch for testing its operation, and a 3,000-pellet storage capacity. The dispenser uses a standard 28V DC power source, comes complete with receptacle, and can be custom mounted to most manufacturers' cages. Dimensions: 6"x3.25"x12.75"



Model 80208

### Press Bar Model 80110

Stainless steel construction (.032" thick) ensures long-lasting reliable operation. A micro switch is used to sense a lever press. The force required to move the bar is factory calibrated to be less than 10gm and is field adjustable via counterbalance washers located on the back. Movement required to activate the lever switch is 3mm.



Model 80110

### Liquid Dispenser Model 80201

This drop-type liquid dispenser holds up to 65cc of liquid in a graduated, calibrated closed reservoir. The amount of liquid dispensed can be easily adjusted via the control box, and works off of a standard 28V DC power source. Receptacle included. Dimensions: 4"x2"x1.5"



Model 80201

### Retractable Lever Model 80113

The retractable lever features a smooth running motor to ensure quiet, reliable extension and retraction of the lever. Control of the lever extension and retraction is now accomplished with one output line. The lever activation is monitored with one input line. This simplifies the wiring by reducing the number of external connections.



Model 80113

### Omnidirectional Lever Model 80111

Mounted to the top of the cage, this lever records responses via rod deflection in any direction. The stainless steel rod is 4.75" in length and is .25" in diameter.



Model 80111

## OPERANT CHAMBER ACCESSORIES

### White Noise Package Model 15800

This package includes the control, a 7-watt amplifier, and 4 speakers. It features a 31-stage pseudorandom noise generator at 20 to 20,000Hz, filtered to remove square wave spikes.



### White Noise Control Model 15800C

The White Noise control has a 7-watt amplifier and features a 31-stage pseudorandom noise generator at 20 to 20,000Hz filtered to remove square wave spikes.

### Sonalert Model 80223

The Sonalert provides a 2,800Hz tone at 80dB for use as an auditory stimulus. Amplitude can be adjusted by varying the voltage supplied. See Tone Intensity Module Model 81407TM on page 6.



### Stimulus Light Model 80221

This light features a large, 1" white frosted lens for distinct CS presentations, and works off of a standard 28VDC power source. To control light intensity in 7 discrete steps, use Light Intensity Module Model 81407LM on page 6.



### 28 Volt Power Supply Model 83619

This 2A power supply will operate 2 or more operant cages. Multiple power supplies can be combined as needed. Short circuit protection is provided by internal current foldback circuitry.  
Dimensions: 12.75"x9.75"x5.5"

### Basic Photocell Kit Model 81413

This infrared photo beam system is designed to be easily interfaced with the ABET Behavioral Control System or any control system that operates on and provides from 10 - 30 V DC. It uses a separate source and receiver that can be placed up to 12' apart. The output from the device is a normally open switch consisting of an open collector transistor that can switch up to 30 V DC at 100 mA max. Power Source not included.



## OPERANT CHAMBER ACCESSORIES

### Master Shocker Supply Model 82400SS

This constant current shocker features a large display meter and two output levels 0 to 1mA on the front and 0 to 5mA on the back panel. Line voltage required is 105/125V AC and current regulation is 3 percent for a 50KOhm change in subject resistance. Grid Harness Model 80001GH is used to connect the shocker directly to the operant cage or use the Neon Grid Scrambler Model 58020 and Grid Harness Model 80240A. Dimensions: 10"x7"x5.5"



### Master Shocker with Scrambler Model 82404SS

This model features either a direct 0 to 5mA output, or a silent neon scrambled constant 0 to 1mA with zero crossover. A built in interrupter pulses the shock output within a 1-second interval, (5-100% of 0.05-1 second adjustments). Line voltage required is 105/125VAC and current regulation is 3 percent for a 50KOhm change in subject resistance. The voltage regulator limiter prevents outputs from rising above 1600V at no load. Direct output from the 5-way binding post is a bipolar 60Hz sine wave. Grid Harness Model 80240A is used to connect the shocker to the operant cage. Dimensions: 19"x7"x6"



### Constant Current Shocker Model 58006

This simple unit delivers up to 1mA of current to any subject 100,000 Ohms or less. Line voltage required is 105/125V AC. Current regulation is 2.5% for a 50KOhm change in subject resistance. Use as is for direct shock or with Neon Grid Scrambler Model 58020. Dimensions: 6"x5.75"x4.75"



### Neon Grid Scrambler Model 58020

This device can be used with any of our shocker units. Noiseless scrambled shock is provided for up to 2mA. Use Grid Harness Model 80240A to attach to the operant cage. Dimensions: 6"x6"x4.5"



### Basic AirPuff Unit Model 80108

#### AirPuff Air Delivery Tubes Model 80109

The AirPuff system provides air puff stimulation as an alternative to electrical shock. Each unit features two gas solenoids, timing controls, switch for optional manual operation, indicator lights and adjustable air delivery tubes. The air stream may be remotely started and stopped by almost any conventional control signal. Stimulation may be delivered as a series of air puffs by adjusting the timing controls to set the duration of each puff and the interpuff interval. A user supplied air source is required.





## SOUND ATTENUATION CUBICLE

**Standard Chamber Cubicle - Model 83015A**

**Large Chamber Cubicle - Model 83017**

**Multiple Chamber Cubicle - Model 83016**

These sound attenuating cubicles feature moderately expanded PVC foam panels that resist moisture and many chemicals. All outside walls are 0.75" (19 mm) thick. Several features improve access to the animal while at the same time reducing incursion of light and sound. The fully removable door features an air and light tight seal around the entire frame and a red tinted window (standard feature) that allows the investigator to look in without allowing the animal to look out. Metal offset baffles are provided for the exhaust fan, air inlet, and cable porthole. The slide out tray makes this cubicle usable with both front and top loading chambers. A 24V DC house light is included with each cubicle.

### Features:

- Moderately Expanded PVC Foam Panels
- **Fan:** 24V DC rated at 34 CFM
- **House Light:** 24V DC @ 100 ma
- Easy-Glide metal tray catches spilled waste and improves animal access
- Removable doors with red tinted, double pane window
- Optional non-windowed doors, door peepholes, tether access hole, and video access hole with metal covers are available on request. (Minimum quantity or additional charge may apply)



Model 83015A

### Technical Specifications:

#### Model 83015A:

##### Overall Outside Dimensions (including fans and baffles):

**Width:** 33" (83.8 cm)

**Depth:** 20" (50.8 cm)

**Height:** 20" (50.8 cm)

##### Working Space with tray:

**Width:** 25" (63.5 cm)

**Depth:** 17" (43.2 cm)

**Height:** 17" (43.2 cm)

Ideal for standard operant chambers

#### Model 83016:

##### Overall Outside Dimensions (including fans and baffles):

**Width:** 72.75" (184.8 cm)

**Depth:** 26.50" (67.3 cm)

**Height:** 24.60" (62.5 cm)

##### Working Space with tray:

**Width:** 68" (172.7 cm)

**Depth:** 22" (55.9 cm)

**Height:** 22.5" (57.2 cm)

Use with Multiple test chambers



## SOUND ATTENUATION CUBICLE (CONTINUED)

### Technical Specifications (continued):

#### **Model 83017:**

##### **Overall Outside Dimensions (including fans and baffles):**

**Width:** 34.75" (88.3 cm)  
**Depth:** 29.25" (74.3 cm)  
**Height:** 25.60" (65.0 cm)

##### **Working Space with tray:**

**Width:** 28.50" (72.4 cm)  
**Depth:** 22.75" (57.8 cm)  
**Height:** 22.75" (57.8 cm)

*Use with large operant chambers, rat wheels, open field test stations, etc.*



**Model 83015A**  
 (Test Chamber Model 80003  
 w/ accessories sold  
 separately)

## Space Saver Cubicle – Model 83018

Material and construction of this cubicle are identical to the previous three models. This unit does not have the external offset baffles. Instead the fan is mounted on the inside and the air baffle and cable holes are straight through with flush mounted panels. The single removable door is replaced with double doors that are supported by full-length hinges. Each door has it's own covered peephole. The top is provided with covered tether and video access ports. This cubicle was designed to take up a minimum amount of space and still be used with a standard test chamber.

#### **Model 83018:**

##### **Outside Dimensions:**

**Width:** 25" (63.5 cm)  
**Depth:** 16" (40.6 cm)  
**Height:** 17" (43.2 cm)

##### **Working Space with tray:**

**Width:** 22.25" (56.5 cm)  
**Depth:** 13.25" (33.7 cm)  
**Height:** 15" (37.8 cm)



## RAT AND MOUSE 9-HOLE BOXES

9-Hole Box – Rat Model 80600

9-Hole Box – Mouse Model 80610

### General Features:

- Sound/light attenuating casing
- Ventilation fan
- Stainless steel and perspex operant chamber
- Grid floor and removable tray on baseboard
- Pellet or liquid dispenser
- Reinforcement tray
- Nine holes with lamps or LEDs
- IR-beam detection of nose poke
- Electronic brightness control
- Housetlight and loudspeaker in roof
- 10m cable
- IR activity monitoring (mouse box only)



The Lafayette Instrument Co. 9-hole box-rat is the same box cited in over 60 published papers by T.W. Robbins and others. The 9-hole box-mouse retains all the features of the rat box refined and developed specifically for mouse operant studies. Both boxes include improvements to be more easily maintained and cleaned.

This novel variation on the conventional operant chamber is used primarily for the serial 5-choice reaction time task. The nose-poke response is rapidly trained and is easier than a lever-press for the animal to execute. Nine responses can be used, rather than the usual two, allowing for the study of response sequencing. Reaction times can be separated from movement times by requiring the animal to hold its nose in one hole until signalled to move to another. Lateralisation can be studied by presenting brief stimuli to the periphery while the animal is required to hold its nose in the central hole. Discrimination can be studied parametrically by varying brightness and position of stimulus, and attention can be tested with the use of distracting lights or noises. These are just a few of the tasks to which the apparatus has been successfully applied. For a review of the 5-choice serial reaction time task see T.W Robbins, *Psychopharmacology*, (2002) 163, 362-380.

### 9-Hole Box for the Mouse Model 80610

**The mouse 9-hole box is the only mouse operant chamber with associated published data for an attentional task for mice** (Humby, Laird, Davies and Wilkinson, *European Journal of Neuroscience*, Vol. 11, pp. 2813-2823, 1999).

The task – the serial 5-choice reaction time task (also available in human and monkey CANTAB) - is a test of sustained and selective attention, which has been well characterized in the rat and has shown clinical validity in a variety of settings, including attentional deficits in Alzheimer's disease patients. It is the first in what is expected to be a growing set of operant based tests in mice, allowing the exploitation of molecular genetics methods in unraveling the genetic contribution to complex psychological and behavioral processes.







## RAT AND MOUSE 9-HOLE BOX

### Sound Attenuating Cubicle

The 9-hole box sits on an aluminum pull-out tray, which slides easily in and out of a sturdy light/sound attenuating cubical made of moderately expanded PVC panels. This permits easy cleaning and maintenance. The cubical is equipped with a ventilating fan, external connectors for power and electronics interfacing, and an observation peephole.

### Behavior Network Control System

The Behavior Network Control (BNC) hardware and software system permits the independent control of a number of operant chambers. The hardware includes a 14A power supply to power the operant chambers.

The intuitive graphical programming language allows for fast, easy and flexible programming. Pre-written standard schedules are also available.

### Behavior Network Control (BNC)

A compact single unit, which is connected to the operant chambers via patch panels. There are 144 I/O lines available, configurable as I or O in blocks of 8 at the time of manufacture. The patch panelling makes it easy for the user to configure and change the system to make effective use of the I/O lines available.

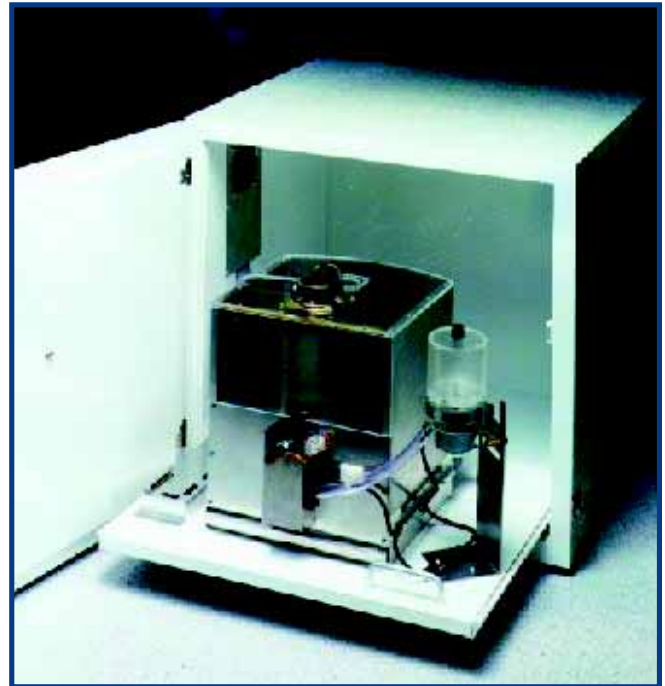

### BNC Professional

A robust system made from industrial grade components. Operant chambers are plugged directly into the system (no patch panelling required).

### Standard Schedule for the 9-Hole Box

#### Serial 5-Choice Reaction Time task

This Behavior Network Control schedule gives the user the flexibility needed to set up and run the serial 5-choice reaction time task for either rat or mouse. The tasks are: variable ITI, variable stimulus brightness, variable stimulus duration and variable temporal position of a distracter. All parameters are independently selectable for each subject and the details are kept in a file for each subject.

## BEHAVIOURNET CONTROL (BNC) SYSTEM

BehaviourNet Control has been designed to overcome the challenges not met by other operant control systems:

### Challenges not met with existing operant control systems:

- Reliance on programming knowledge
- Long debugging process
- Compliance with GLP regulations - security of data, lack of a clear auditing trail
- Having to anticipate the right data questions at the start
- Complex task set up
- Speed constraints - missing data

### The Solutions:

- An easy to use **graphical scheduling** language that does not constrain programming
- **Simulation** program, which allows schedules to be thoroughly tested away from the lab
- **Data security** - all data encrypted, schedules and data can be locked
- **Automatic storage** of all input data
- **Drop down lists** of approved tasks and settings; enforced default data entry at start of experiment
- A dedicated PC with real-time embedded software to ensure **fast and secure data collection**

### The BNC Mk1

The 9-hole chambers are attached to the BNC via optional 2mm plugs attached to the PC via a Local Area Network and several Control Units may be operated from one PC.

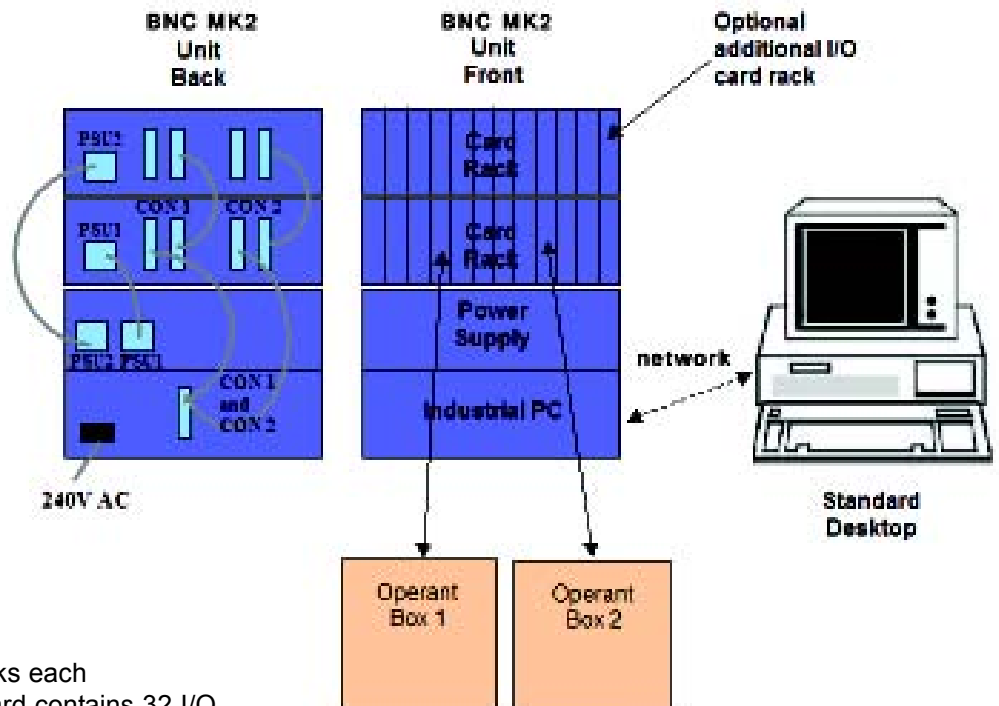

### The BNC Mk2

A system can have one or two I/O racks each containing up to 12 I/O cards. Each card contains 32 I/O lines, user configurable as I or O in blocks of eight.

The industrial PC contains embedded real time software.

The power supply is a high-grade industrial power supply – input voltage 110V/240V, supply voltage 24V DC / 24A. A double unit containing two 24V supplies is also available, to drive a two card rack system.

The data handling software is installed on a standard PC (or PCs) and communicates with the BNC Mk2 control unit via a network cable or hub.

### The I/O rack

Each card has 4 banks of 8 inputs or outputs. These can be configured by the user as I or O via a dip switch.





## BEHAVIOURNET CONTROL (BNC) SYSTEM SOFTWARE

The data handling software is Windows 2000 and XP compatible and runs on most modern PC's. It communicates through a network to the controller PC, which has real-time embedded software to run the experiments. There are five independent elements to the data handling software:

### BNC Designer - a graphical programming environment

The user interface allows easy construction and understanding of tests. Easily learned - no prior programming knowledge needed. A selection of library calls, including randomisation and pseudo-randomisation functions, makes it possible to create even very complex programs.

### The BNC Simulator - for fast testing and debugging of programs

A program can be simulated from within the BNC Designer. A graphical representation of the program shows exactly which parts of the program are in progress. This means that if the program is failing at any point, the fault in the program can be quickly identified and altered.

### The BNC Settings Editor - allows you to easily change variables

The programming element of the system allows for certain things to be set from outside the program. This includes not only simple variables such as values set for timers, but also more complicated elements such as which elements are included in a set, whether a certain path in a program is followed, how many trials are followed. The variables can also be set individually for each trial. It is even possible to jump to different trials according to a response. For example, a training program can be set up so that when a certain task has been mastered the program can jump to a more complex task. The Settings Editor is designed from the BNC Settings Designer wizard. The Settings Designer allows the researcher to set up which variables can be changed and also allows for limits on these changes. Consequently an assistant can easily set variables within a test, but only according to rules set up by the researcher.

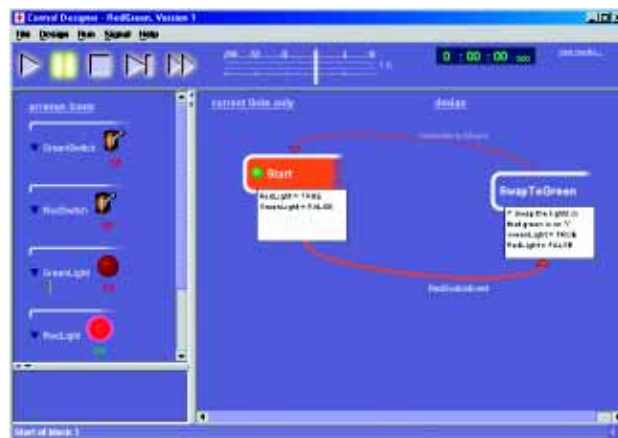

### The BNC Network Manager - from which the tests are run and monitored

The BNC Network Manager helps with the initial set-up of the hardware. Each of the connected test chambers can be controlled **completely independently**. Additional monitoring columns can be created to add other information relevant to the experiment being run. Constraints can be made on how this is filled in (e.g. numerical values only) and filling in the data can be made compulsory before the test will run.

### The BNC Results Manger – for managing and analysing your data

All data is automatically collected and saved as raw data. All raw data is encrypted to prevent accidental or deliberate changes to the data - very valuable if working to GLP requirements. The data is saved to archives. Which archive data is saved to can be automatically calculated according to user set rules.

The BNC Results Manager enables the easy extraction of relevant data from this mass of raw data by means of filters. Filters extract latencies from the raw data. Filters are easily set-up from the graphical interface and can be created or changed after the experimental data has been collected. Both raw and filtered data can be saved as a spreadsheet ready to transport to such packages as Excel and SPSS. Filtered data can also be exported to a database (e.g. Access or Oracle). The BNC Results Manager also has it's own report generator. Results can be selected, for comparison, from an archive according to user set criteria. The report designer allows spreadsheet report to be created.

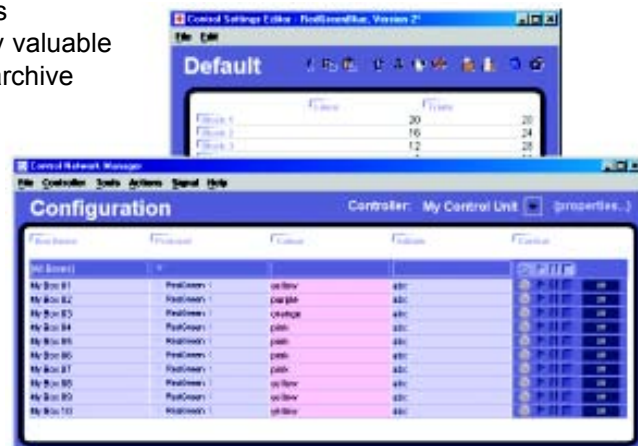



- *Voluntary Wheels for Rat & Mouse*
- *Forced Exercise for Rat & Mouse*
- *Yoked Systems for Rat & Mouse*
- *Counters, Interfaces and Software*
- *All Plastic Running Wheels  
(Additional Information on Request)*

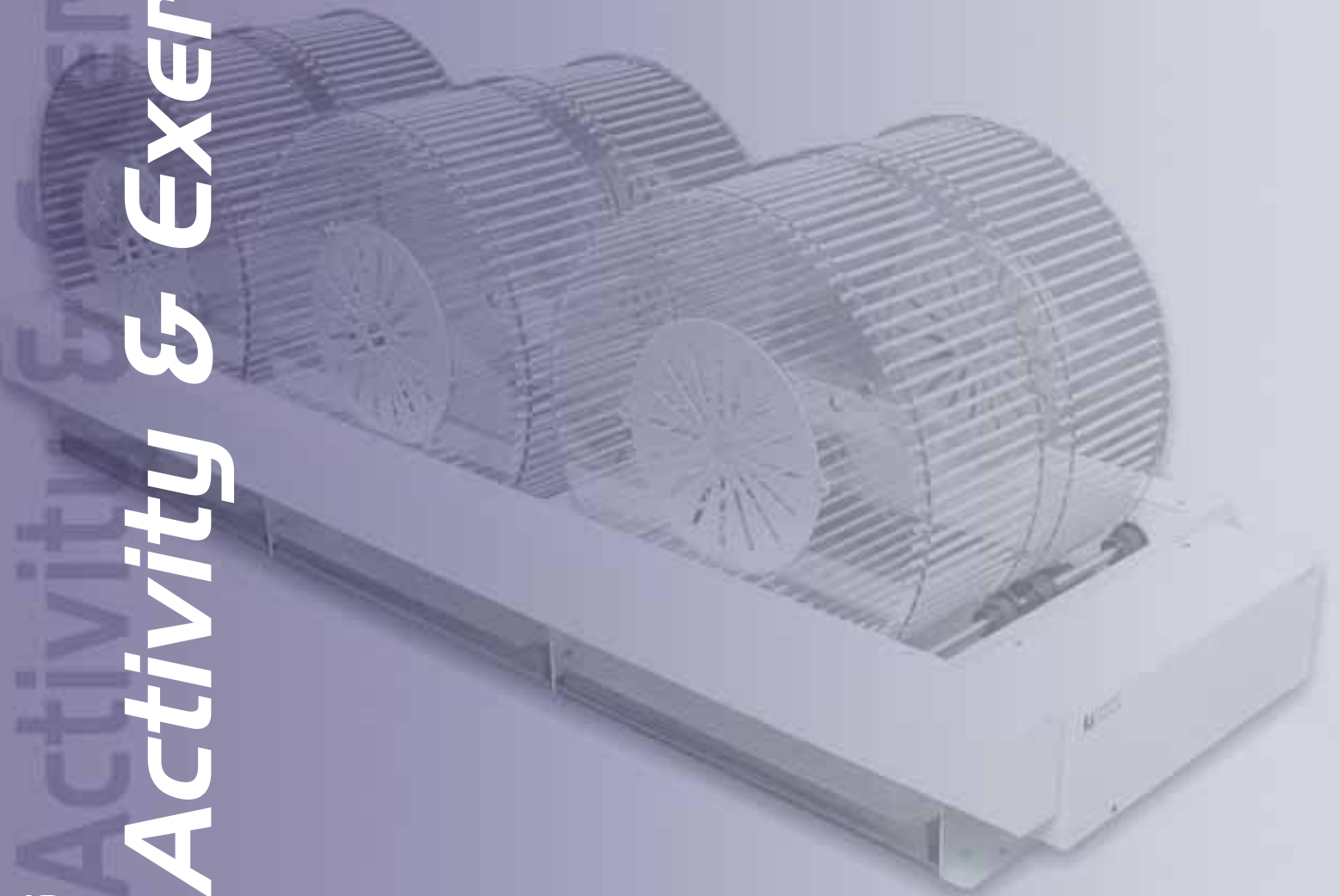



## SINGLE ACTIVITY WHEEL CHAMBER SYSTEM FOR MICE Model 80820

This Single Activity Wheel Chamber System Model 80820 was designed for long-term circadian rhythm and general activity studies. The chamber incorporates many features to allow for animal well-being and easy maintenance of system components. The chamber includes food and water support and includes free access to the activity wheel. The activity wheel can be monitored by one of our optional counter modules. The counter can also report activity data to a computer using our Activity Wheel Monitor Starter and Expander Interface Model 86056 and Model 86057.

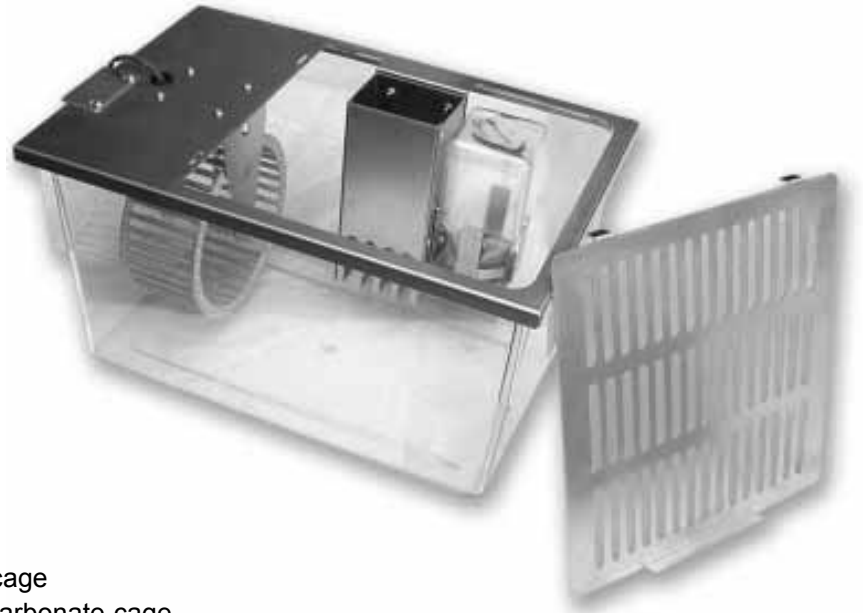

### Features:

- Uses 9.3" x 13.9" x 7.7" clear polycarbonate cage
- Stainless steel top cover lays flush onto polycarbonate cage
- All components are secured to top cover for one step removal
- Feeder and water bottle are attached to top cover allowing for easy access
- Feeder has sighting slot on back to view feed level
- Removable lightweight 5" diameter anodized aluminum wheel is easy to clean and maintain and is run on two Rulon bearings
- Equipped with external mounting bracket for mounting of an optional electronic counter
- Removable stainless steel vented access hatch allows for easy access to the animal
- Complete chamber can be easily disassembled for cleaning

### Technical Specifications:

<b>Dimensions:</b>	9.3" x 13.9" x 7.7"
<b>Weight:</b>	3.0lbs.
<b>Wheel Diameter:</b>	5.0" ID
<b>Run Distance:</b>	0.40 meters/revolution



### Options:

- **Model 86060** - Activity Wheel Counter with digital display for stand alone use or computer interface.
- **Model 86061** - Activity Wheel Counter for computer interface only (includes 86051-7 cable).
- **Model 86070** - Activity Wheel Counter with motor, brake, and auxiliary control (includes 86051-7 cable).
- **Model 86070-B1** - Activity Wheel Servo Controlled Brake
- **Model 86051-7** - Seven-foot cable for connection between the counter and the counter interfaces Model 86056 or Model 86057
- **Model 86051-14** - Fourteen-foot cable for connection between the counter and the counter interfaces Model 86056 or Model 86057



## LARGE RAT ACTIVITY WHEEL SYSTEMS

### Activity Wheel Model 80850

### Optional Living Chamber Model 80852

### Optional Loading Cage Model 80854

This Rat Activity Wheel System was designed for long-term circadian rhythm and general activity studies. The system incorporates many features to allow for animal well-being and easy maintenance of system components. The Optional Living Chamber Model 80852 includes support for food and water and includes guillotine style doors to restrict access to the activity wheel. The rat activity wheel can be monitored with either the Computerized Activity Wheel Counter (read only) Model 86061 or the Stand Alone Activity Wheel Counter Model 86060. These counters can also report activity data to a computer using our Activity Wheel Monitor Starter and Expander Interfaces Model 86056 and Model 86057.



### Features:

- Removable lightweight 14" diameter stainless steel wheel is easy to clean and maintain  
Rulon bearings
- Low friction Rulon bearings
- Optional loading/transport cage
- Optional polycarbonate living chamber with food and water support
- Equipped with external mounting bracket for mounting of an optional electronic counter
- Wheel can be easily disassembled for cleaning

### Technical Specifications:

<b>Dimensions:</b>	15.6" x 14.2" x 5.3"
<b>Weight:</b>	6.0lbs.
<b>Wheel Diameter:</b>	14.0" ID
<b>Wheel Width:</b>	4.3" (internal)
<b>Run Distance:</b>	1.10 meters/revolution

### Options:

- **Model 80852** - Optional Living Chamber for the Rat Activity Wheel Model 80850
- **Model 80854** - Optional Animal Loading Cage for the Rat Activity Wheel Model 80850
- **Model 86060** - Activity Wheel Counter with digital display for stand alone use or computer interface.
- **Model 86061** - Activity Wheel Counter for computer interface only (includes 86051-7 cable).
- **Model 86070** - Activity Wheel Counter with motor, brake, and auxiliary control (includes 86051-7 cable).
- **Model 86070-B1** - Activity Wheel Servo Controlled Brake
- **Model 80851** - Activity Wheel Motor Drive
- **Model 86051-7** - Seven-foot cable for connection between the counter and the counter interfaces Model 86056 or Model 86057
- **Model 86051-14** - Fourteen-foot cable for connection between the counter and the counter interfaces Model 86056 or Model 86057



## LARGE RAT ACTIVITY WHEEL SYSTEMS

### Rat Activity Wheel (standard) Model 80859

### Rat Activity Wheel (large) Model 80859L

This Rat Activity Wheel with Living Chamber was designed for long-term circadian rhythm and general activity studies in very large rats and non-rat rodents. This system incorporates many features to allow for animal well-being and easy maintenance of system components. The living chamber includes support for food and water. The rat activity wheel can be monitored with either the Computerized Activity Wheel Counter Model 86061, or the Activity Wheel Counter Model 86060 with digital display. These counters can also report activity data to a computer using our Activity Wheel Monitor Starter and Expander Interfaces Model 86056 and Model 86057.



### Features:

- Equipped with external mounting bracket for mounting of an optional electronic counter
- Wheel can be easily disassembled for cleaning

### Model 80859 Specifications:

**Tub Dimensions:** 16.0" x 20.0" x 8.25"  
**Weight:** 6.0lbs.  
**Wheel Diameter:** 14.0" ID  
**Wheel Width:** 4.3" (internal)  
**Run Distance:** 1.10 meters/revolution

### Model 80859L Specifications:

**Tub Dimensions:** 16.0" x 20.0" x 8.25"  
**Weight:** 7.0lbs.  
**Wheel Diameter:** 18.0" ID  
**Wheel Width:** 5.25" (internal)  
**Run Distance:** 1.44 meters/revolution

### Options:

- Model 86060 - Activity Wheel Counter with digital display for stand alone use or computer interface.
- Model 86061 - Activity Wheel Counter for computer interface only (includes 86051-7 cable).
- Model 86070 - Activity Wheel Counter with motor, brake, and auxiliary control (includes 86051-7 cable).
- Model 86070-B1 - Activity Wheel Servo Controlled Brake
- Model 86051-7 - Seven-foot cable for connection between the counter and the counter interfaces Model 86056 or Model 86057
- Model 86051-14 - Fourteen-foot cable for connection between the counter and the counter interfaces Model 86056 or Model 86057





## TETHERED ACTIVITY WHEELS

- Motorized Tethered Rat Wheel Model 80860**
- Tethered Rat Wheel without Motor Model 80860W**
- Wheel Motor Model 80860M**

The Tethered Rat Activity Wheel features durable construction from stainless steel and polycarbonate components. The motorized unit uses a non-slip shock absorbing drive belt for forced exercise that is easily removed for free running data collection. The fold down side provides easy placement and removal of the tethered animal. The narrow side slot will accommodate a drug line or electrode cable connected to a standard swivel or commutator (tethers, swivels, and commutators sold separately). These systems also incorporate ad lib access to both food and water to allow for the animal's well being. A stainless steel waste pan and water bottle with sipper tube are included. An optional brake Model 86070-B1 is also available for use with the wheel in a free wheeling setup. The motorized wheel and/or optional brake must be used with the 86070 Counter and Controller. Motor and Brake can not be used simultaneously. The Tethered Rat Wheel without Motor may be used with the 86060 Counter with Digital Display or 86061 Counter for Computer Interface Only.

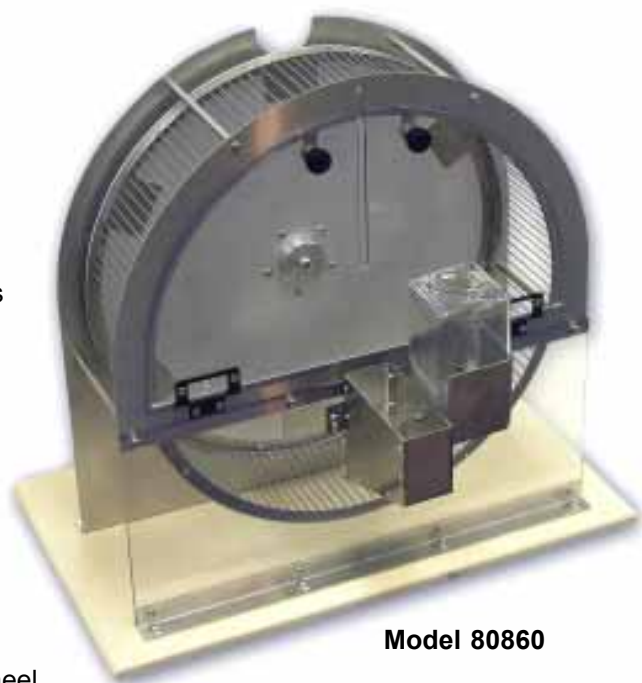

**Model 80860**

- Motorized Tethered Mouse Wheel Model 80840**
- Tethered Mouse Wheel without motor Model 80840W**
- Wheel Motor Model 80860M**

These wheels are scaled down versions of the above wheels with comparable features and options.

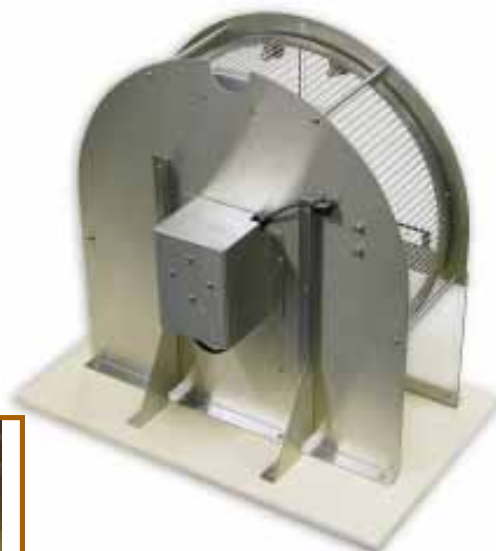

**Model 80860W**

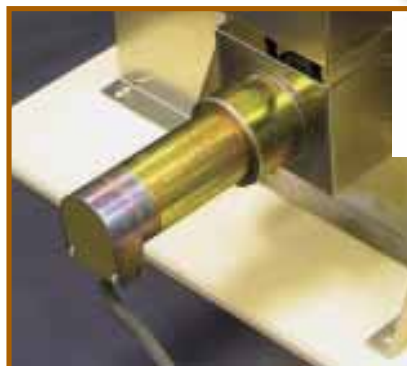

**Model 80860M**

### Technical Specifications:

#### Dimensions:

Rat: 18" x 14" x 10"

Mouse: 10" x 14" x 10"

#### Wheel Diameter:

Rat: 14.0"

Mouse: 6.75"

#### Wheel Width (internal)

Rat: 4.3"

Mouse: 2.25"

#### Run Distance:

Rat: 1.10 meters per revolution

Mouse: 0.47 meters per revolution

#### Weight:

Rat: 7 lbs.

Mouse: 4.5 lbs.

### Options:

- Model 86070 - Activity Wheel Counter and Control
- Model 86060 - Activity Wheel Counter with Digital Display
- Model 86061 - Activity Wheel Counter Only
- Model 86056 - Activity Wheel Monitor Starter Interface with AWM Software
- Model 86057 - Activity Wheel Monitor Expander Interface
- Model 86051-7 - 7' Interface Connection Cable for Model 86060
- Model 86051-14 - 14' Interface Connection Cable



## TETHERED ACTIVITY WHEEL ACCESSORIES

### Activity Wheel Counter/Controller Model 86070

The Activity Wheel Counter/Controller Model 86070 is used to monitor and control the revolutions of Lafayette Instrument Co. Tethered Activity Wheels. The Model 86070 uses optical sensors to detect the total revolutions of the wheel. For collection of data from the Model 86070, the Model 86056 AWM Starter Interface must be used. The Model 86056 will provide power and a serial port computer connection. Up to 15 Model 86070 counters may be connected to the Model 86056 and up to 120 total counter/controllers may be connected using seven Model 86057 Expander Interfaces. The Model 86070 Counter/Controller provides outputs for a drive motor, brake and auxiliary device such as a house light.

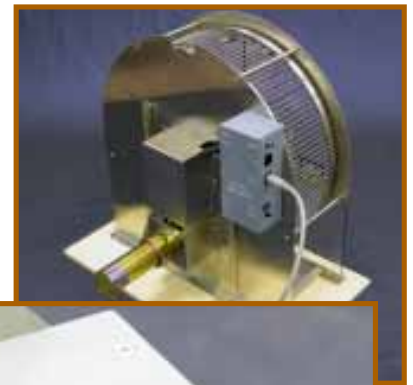

#### Technical Specifications:

- Power:** Provided Power Pack +15VDC
- Revolution Count:** 10,000,000 Maximum
- External Interface:** RS-232C interface to computer through Model 86056 Interface  
19200 baud, no parity, 8 data bits, 1 stop bit

### Activity Wheel brake Model 86070-B1

The Lafayette Activity Wheel Brake Model 86070-B1 is used as an on/off and resistance braking for the Lafayette activity wheels. The Activity Wheel Brake is controlled through the Activity Wheel Counter, Model 86070, and is used in applications to impede an animal's ability to run. When used in conjunction with the Lafayette Activity Wheel Software, Model 86065 and Starter Interface, Model 86056; the Activity Wheel Brake can be programmed to activate and deactivate upon the users' request.



#### Parts included:

- Model 86070-B1 - Brake Housing
- On/Off Brake
- Resistance Brake

#### Technical Specifications:

**Power:** Provided through the Activity Wheel Counter (Model 86070)

**Computer Control:** Lafayette Activity Wheel Software v5.1 or higher via the Starter Interface (Model 86056)



## ACTIVITY WHEEL INTERFACES AND SOFTWARE

### Activity Wheel Monitor Starter Interface Model 86056

This Activity Wheel Monitor Starter Interface Model 86056 provides a computer connection for up to 15 Activity Wheel Counters Model 86060 or Model 86061. The counters connect through 6-pin modular cables to the starter interface, which connects to the computer through a serial communications port. The starter interface may be expanded with an Activity Wheel Monitor Expander Interface Model 86057 to support an additional 15 counters per expander interface. Up to seven expander interfaces can be connected to the Starter Interface to accommodate a maximum of 120 counters. This starter interface includes a software program (Activity Wheel Monitor Software) to download the information from the counters at regular intervals over a specified period of time.



Model 86056

#### Technical Specifications

**Power:** 12VDC Supply (Included)  
**# of counters:** 15  
**External Interface:** RS-232C interface to computer 19200 baud, no parity, 8 data bits, 1 stop bit  
**Dimensions:** 3.9" x 9.0" x 1.6"  
**Weight:** 1.6lbs.

### Activity Wheel Monitor Expander Interface Model 86057

This Activity Wheel Monitor Expander Interface Model 86057 provides a computer connection for up to 15 Activity Wheel Counters Model 86060 and Model 86061. The counters connect through 6-pin modular cables to the expander interface, which then connects to the Activity Wheel Monitor Starter Interface Model 86056. Up to seven expander interfaces can be connected to the starter interface to accommodate a maximum of 120 counters.

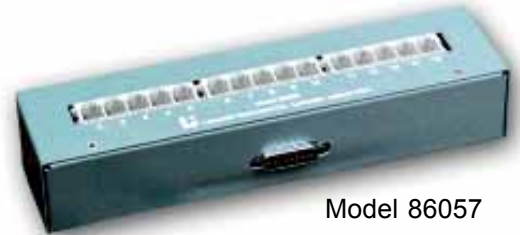

Model 86057

#### Technical Specifications:

**Power:** 12VDC Supply (included)  
**# of counters:** 15  
**External Interface:** RS-232C interface to computer through 86056 interface 19200 baud, no parity, 8 data bits, 1 stop bit  
**Dimensions:** 2.3" x 9.0" x 1.7"  
**Weight:** 1.2lbs.

### Activity Wheel Monitor Software Model 86065

(Included with the purchase of starter interface, Model 86056)

- **Data bin time intervals:** from 1 minute to 24 days
- **Length of experiment:** 1 minute to 61 days
- Each counter can be assigned two ID values {First value: A-Z or 1-8, Second value: 1-120} for clarity and added data separation
- Allows Real Time Activity logging for each wheel
- Comma Separated Data File, opens with MS Excel or other word processing program
- Optional export to Excel of total data plus macro generated interval count, speed, and distance sheets; and interval count and total count charts.
- Extensive help file with screen shots to answer any questions

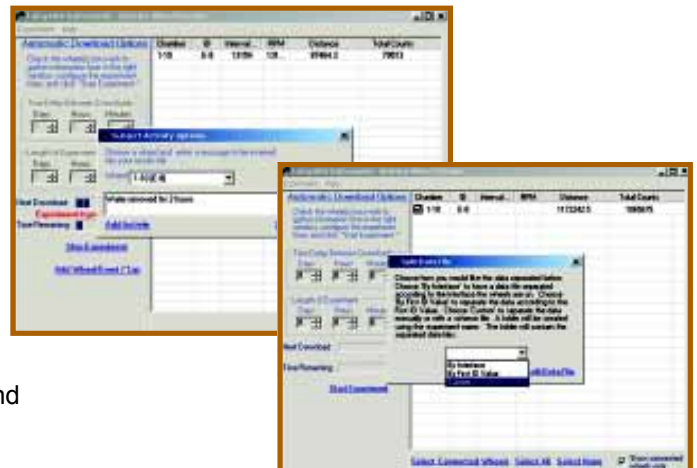





## ACTIVITY WHEEL COUNTERS

Model 86060

### Activity Wheel Counter Model 86060

The Activity Wheel Counter Model 86060 is used to monitor the revolutions of the Single Mouse Activity Wheel Model 80820 & 80840W or Single Rat Activity Wheels Model 80850, 80859, 80859L & 80860W. It will also work with older wheels such as Model 86043 and some wheels from other manufacturers. All Lafayette Instrument company wheels use an optical sensor to detect the total revolutions of the wheel. Data may be downloaded from the 86060 Activity Wheel Counter using the Starter Interface Model 86056 and Expander Interface Model 86057 and the AWM software package, or from the pulse output jack using any compatible interface and your own software. The Animal Wheel Monitor Starter Interface Model 86056 will provide power and a serial port computer connection. Up to (15) Activity Wheel Counters Model 86060 may be connected to the Animal Wheel Monitor Starter Interface Model 86056 and up to (120) total counters may be connected using (7) Animal Wheel Monitor Expander Interfaces Model 86057. The Activity Wheel Counter Model 86060 provides standalone operation with a 12V power pack with battery backup and an LCD display. When battery backup power is used, battery life is two days.



#### Technical Specifications:

<b>Power:</b>	12VDC power pack or provided through the Animal Wheel Monitor Starter Interface Model 86056 or Animal Wheel Monitor Expander Interface Model 86057
<b>Battery Type:</b>	(2) 2/3A Lithium 3VDC
<b>Battery Life:</b>	48 hours of back-up life, un-used life is 5 years
<b>Total Revolutions:</b>	Unlimited - counter rollover value at 9,999,999
<b>External Interface:</b>	RS-232C interface to computer through Animal Wheel Monitor Starter Interface Model 86056. 19,200 baud, no parity, 8 data bits, 1 stop bit
<b>Pulse Output:</b>	20 ms active low via 3 pin mini jack providing open collector, gnd, and +5V through a 100K pull up resistor
<b>Dimensions:</b>	2.5" x 4.3" x 1.5"
<b>Weight:</b>	9.6 ounces

#### Options:

- **Model 86051-7** - Seven-foot cable for connection between the counter and the counter interfaces (86056 or 86057)
- **Model 86051-14** - Fourteen-foot cable for connection between the counter and the counter interfaces (86056 or 86057)
- **Model 86060C** - This cable is used to connect the optical activity wheel counters Model 86060 or Model 86061 with the magnetic sensing Rat Activity Wheel Model 86043.
- **Model 3-913-003** - Power supply AC adapter (one included)

### Computer Controlled Activity Wheel Counter Model 86061

The Activity Wheel Counter, Model 86061 is used to monitor the revolutions of the Single Mouse Activity Wheel, Model 80820; Single Rat Activity Wheels, Model 80850, 80859 and 80859L; or the Single Rat Activity Wheel, Model 86043. This counter uses optical sensors to detect the total revolutions of the wheel. For collection of data from the 86061, the 86056 AWM Starter Interface must be used. The 86056 will provide power and a serial port computer connection. Up to 15 86061 counters may be connected to the 86056 and up to 120 total counters may be connected using 7 86057 Expander Interfaces. A Model 86051-7 Cable is included with each unit.

#### Technical Specifications

<b>Power:</b>	Provided through the Animal Wheel Monitor Starter Interface Model 86056 or Animal Wheel Monitor Expander Interface Model 86057.
<b>Total Revolutions:</b>	Unlimited - counter rollover value at 9,999,999
<b>External Interface:</b>	RS-232C interface to computer through Animal Wheel Monitor Starter Interface Model 86056 no parity, 8 data bits, 1 stop bit
<b>Dimensions:</b>	1.7" x 3.4" x 1.5"
<b>Weight:</b>	4.5 ounces

#### Options:

- **Model 86051-14** - Fourteen-foot cable for connection between the counter and the counter interfaces Model 86056 or Model 86057
- **Model 86060C** - This cable is used to connect the optical activity wheel counters Model 86060 or Model 86061 with the magnetic sensing Rat Activity Wheel Model 86043



Model 86061





## SPECIALTY EQUIPMENT

### Rat Forced Exercise/Walking Wheel System Model 80805

The Forced Exercise/Walking Wheel System for Rats Model 80805A is designed to offer flexibility in conducting paradigms such as sleep deprivation and forced exercise. The sturdy exercise/walking bed will support up to (6) Rat Exercise/Walking Wheels Model 80806 and incorporates removable waste pans. The wheels incorporate a swing-hatch for easy animal loading and removal. The wheels rest on individual tracks with cushioned non-slip grips. The LCD interface allows the user to set the exercise/walking speed, run/test intervals, and the total cycles/exercise time. (Order wheels separately.)

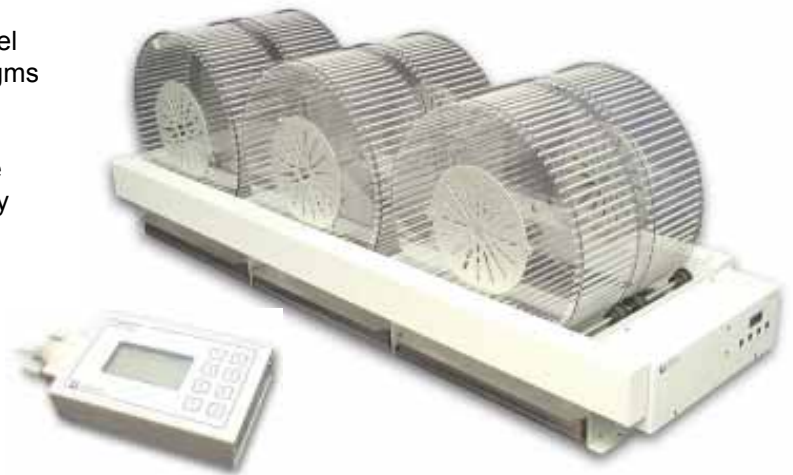

#### Features:

- Supports one to six wheels at a time
- Each wheel is captured in its own running track
- Each wheel is supported on cushioned non-slip grips
- System has a variable speed range
- Three removable stainless steel waste pan
- Wheels can be added or removed while operating
- System has rubber feet or can be permanently mounted to a flat surface or workbench
- System is easily disassembled for cleaning
- Water support for each animal may be added
- Programmable test/rest times
- Programmable number of cycles (test/rest)

#### Technical Specifications

**Power:** 15VDC, 4.6A Power Pack (included)  
**Dimensions:** 51.0" x 17.9" x 16.9" (with wheels)  
**Weight:** 20.0lbs. (empty), 41.0lbs. (with 6 wheels)  
**Wheel Diameter:** 13.38" ID  
**Wheel Width:** 4.4" ID  
**Run Distance:** 1.07 meters/revolution  
**Speed Ranges:** 1.0 - 30 meters/minute (in 0.5 m/m increments)  
**Exercise Time Range:** 1 minute to 24 hrs

### Rat Exercise Walking Wheel Model 80806

#### Features:

- Wheels are 4.4" internal width with an internal running diameter of 13.38"
- Wheels are lightweight yet sturdy
- Wheel sides are polycarbonate plastic with riveted anodized aluminum round rungs
- Thumbscrew locking swing hatch is made from anodized aluminum
- Access for animal loading and removal is 6.5"



#### Technical Specifications

**Weight:** 3.5lbs.  
**Wheel Diameter:** 13.38" ID  
**Wheel Diameter:** 14.19" OD  
**Wheel Width:** 4.4" (internal)  
**Wheel Width:** 4.9" (external)

### Rat Water Support Model 80807

A bracket, bottle and sipper tube for use on the forced exercise wheel bed.



## SPECIALTY EQUIPMENT

### Mouse Forced Exercise/Walking (20) Wheel System Model 80800A

### Mouse Forced Exercise/Walking (10) Wheel System Model 80800A-10 (not shown)

The Forced Exercise/Walking Wheel System for Mice is designed to offer flexibility in conducting paradigms such as sleep deprivation and forced exercise. The sturdy exercise/walking beds will support up to 10 or 20 Mouse Exercise/Walking Wheels Model 80801 and incorporate a removable waste pan. The wheels incorporate a swing-hatch for easy animal loading and removal. The wheels rest on individual tracks with cushioned non-slip grips. The LCD interface allows the user to set the exercise/walking speed, run/test interval, and the total cycles/exercise time.



Model 80800A with Wheels and PsymCon control

#### Features:

- Supports 1 - 10 (Model 80800A-10) or 1 - 20 wheels (Model 80800A) at a time
- Each wheel is captured in its own running track
- Each wheel is supported on cushioned non-slip grips
- System has a variable speed range
- Large removable stainless steel waste pan
- Wheels can be added or removed while operating
- System has rubber feet or can be permanently mounted to a flat surface or workbench
- System is easily disassembled for cleaning
- Programmable test/rest times
- Programmable number of cycles (test/rest)

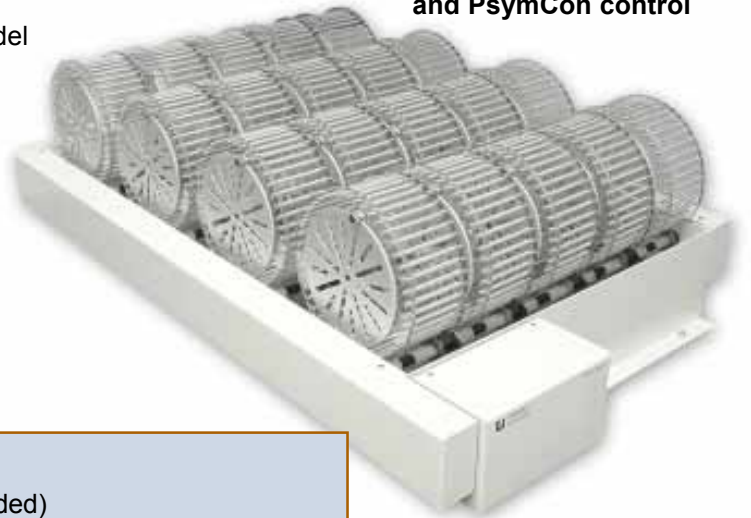

#### Technical Specifications

<b>Power:</b>	15VDC, 2.0A Power Pack (included)
<b>Dimensions:</b>	33.9" x 22.25" x 10.875" (with wheels)
<b>80800A-10 Dimensions:</b>	19.25" x 22.25" x 10.875" (with wheels)
<b>Weight:</b>	25.0lbs. (empty), 41.0lbs. (with 20 wheels)
<b>80800A-10 Weight:</b>	18.7lbs. (empty), 26.2lbs. (with 10 wheels)
<b>Wheel Diameter:</b>	5.94" ID
<b>Wheel Width:</b>	2.25" ID
<b>Run Distance:</b>	0.47 meters/revolution
<b>Speed Range:</b>	0.9 m/min to 11.4 m/min (in 0.1 m/min increments) optional 1.8 m/min to 21 m/min (in 0.1 m/min increments)
<b>Exercise Time Range:</b>	1 minute to 24 hrs

### Mouse Exercise Walking Wheel Model 80801

#### Features:

- Wheels are 2.25" internal width with an internal running diameter of 5.94"
  - Wheels are lightweight yet sturdy
  - Wheel sides are polycarbonate plastic with riveted anodized aluminum round rungs
  - Thumbscrew locking swing hatch is made from anodized aluminum
- Access for animal loading and removal is 5.0"



#### Technical Specifications

<b>Weight:</b>	0.8lbs.
<b>Wheel Diameter:</b>	5.94" ID
<b>Wheel Diameter:</b>	6.75" OD
<b>Wheel Width:</b>	2.25" (internal)
<b>Wheel Width:</b>	2.75" (external)

# PhotoBeam Activity

- *Motor Monitor Software*
- *OpenField*
- *Cage Racks*
- *Learning Hole*
- *Place Preference*





## THE MOTORMONITOR™ SOFTWARE

### Automated Diagnostics and Built-in Validation Aids

Most commercial systems have some type of beam check, but ours is capable of real diagnosis! The advanced diagnostics interrogate the performance level of the photobeam components. It's much more than a simple on/off test. These sophisticated tests provide 4-level circuit evaluation that ensures proper operation automatically before the start of each session. The system will tell you when photobeam is going to fail before it actually happens! In the unlikely case a photo beam failure does occur, the user may choose to either correct the failure or remove the failed enclosure before continuing. The session will begin only after a successful automatic diagnostic has been completed.

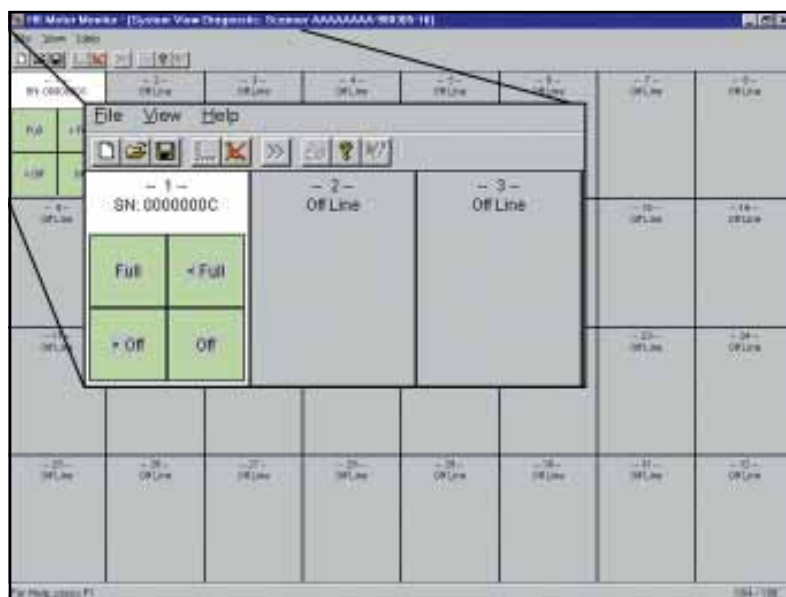

### An Impressive List of Advanced Measures

Each of these measures may be selected or omitted for output to a spreadsheet compatible file. All measures reported are per interval and zone metrics are per interval/per zone.

#### Header Information:

Fixed:

- Data Document
- Enclosure Number
- Interval Number
- Parameters (used in data reduction)

User Selected:

- Date
- Time of Day
- Session Info
- Enclosure Info

#### Movement Metrics:

- Basic Movements (Total Beam Breaks)
- Fine Movements
- X/Y Ambulations
- Events

#### Zone Metrics:

- Distance Traveled
- Total Time in Zone
- Time at Rest
- Entries into Zone
- Pokes into Zone - NEW MEASURE!

#### Zones to Include

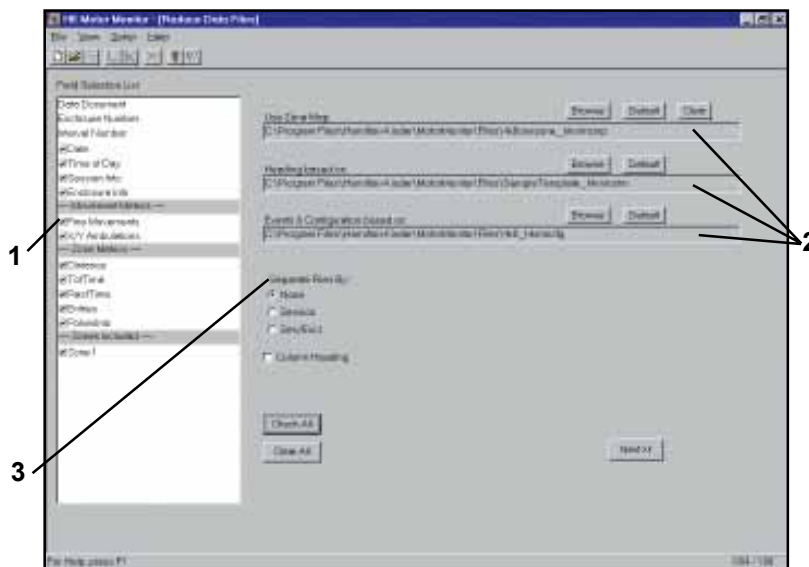

Above is the measures selection screen. From it you can choose any of the measures for exporting (1), select from a list of different Zone maps and configuration files (2), and direct the output data to a single file or separate files sorted by Session or Session and Enclosure (3)





## MOTORMONITOR™ SOFTWARE OPTIONS

### HotSpots™

Acquire instant, graphical comparisons of session results! You no longer need to make assumptions with zone maps! View where animals spend their time, automatically. After you have once viewed the HotSpots, then you can draw a zonemap based on the actual activity. Display data from a single enclosure or from an enclosure ensemble, allowing you to visually compare animals or groups. HotSpots is an activity gradient display, where red represents the hottest activity area and blue the coldest. Activity concentrations which fall between the two extremes follow the color spectrum between red and blue. An extremely powerful aid in analyzing activity behavior!

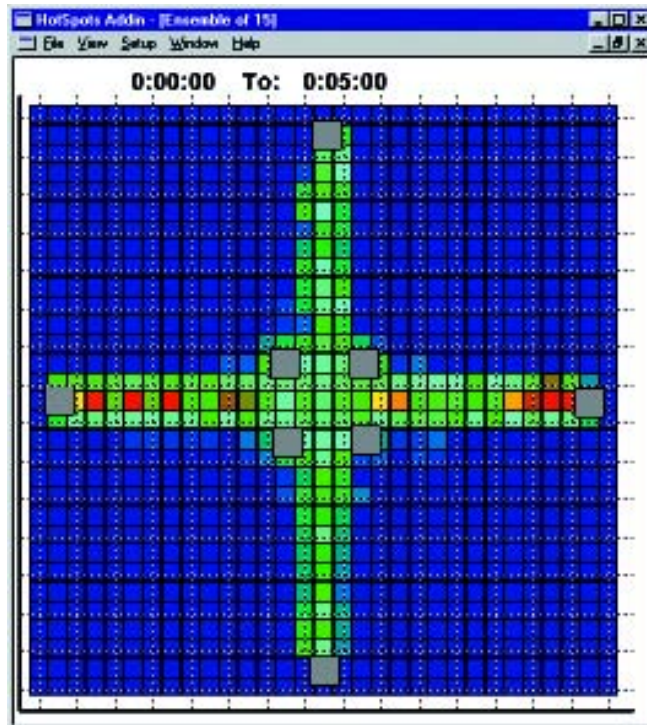

### OverTime™

View the changes in activity Over Time. Chart zone metrics (Total Time, Rest Time, Distance, etc.) for multiple zones. See how an animal or an ensemble of animals change as time changes. This allows establishing baseline expectations as well as displaying a view of the changes that a drug causes over time.

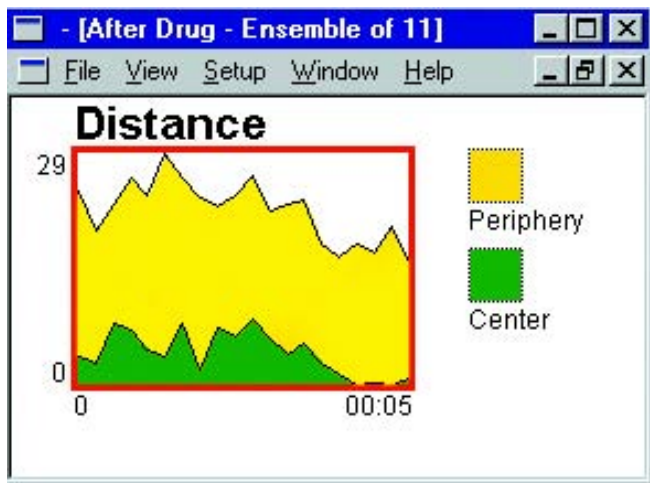

### PlayBack

View the path of an animal from a data document, speed it up if desired. Overlay a compatible zone map and see activity relative to the areas of interest. Set the time sliding time clocks to view only the period of interest. Trace the entire path of the animal and print it. Show events, XY-SW and/or grid; and view animal locations as centroid, points, or oval.

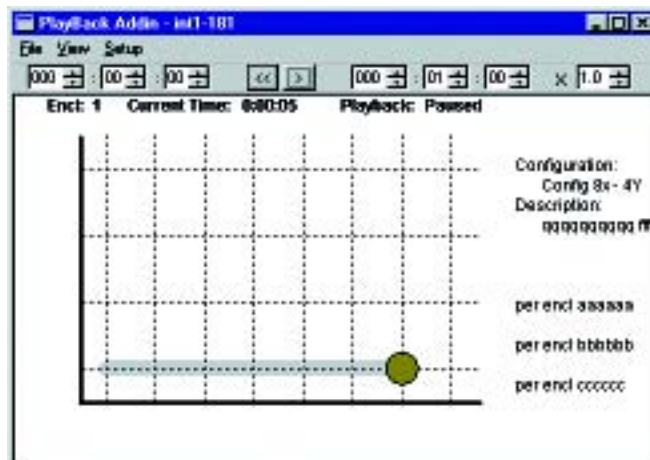



## MOTORMONITOR™ PRODUCTS

The MotorMonitor System and the series of products that it supports are the most advanced units available on the market today. The suggestions of experienced researchers and our years of experience are incorporated into this new line of products. Just look at the wide range of products you can operate from a single system, Please contact a representative at Lafayette Instrument Co. when mixing different test environments on the same system.

***A single system that runs all of these models!!***

### Open Field Systems



Ambulatory Test Station Model HSF16x16  
Optional Rearing Frame Model HHSF16R



Full Isolation Insert Model HV11000



Light/Dark Insert Model HLD2000



Learning Hole Board Model HSF16HB



Cage Rack System Model HSF4x8  
*Not Shown:*  
Rearing Frame Model HSF4x8R  
Light/Dark Insert Model HLD1000



High Density Mouse Cage Rack System Model HSF7x15  
Rearing Frame Model HSF7x15R  
(not shown)

### Anti-Depression and Anxiety



Elevated Plus Mazes:  
Automated Rat Station Model HEMP1001  
Automated Mouse Station Model HEMP2001



Cued & Contextual Fear Conditioning System Model HFC1000



Forced Swim Test – Rat Model HFS1000  
Forced Swim Test – Rat Model HFS2000



# Photobeam Activity

## SMARTFRAME™ OPEN FIELD SYSTEM

The *SmartFrame* Open Field System is designed with the most advanced features available in today's market. It uses Windows NT/2000 compatible *MotorMonitor* software common to most motor activity products with post analysis routines for greater flexibility in analyzing data. The advanced diagnostics use an exclusive 4-level test which runs automatically before each session. Named the *SmartFrame* because of its onboard intelligent circuitry, this system dramatically enhances validation and diagnostic efforts. An excellent choice for open field work for both rats and mice because of its standard high density beam spacing. Systems are also available for larger animals— please consult factory for details.

*“A Classic Open Field System with advanced features”*



**On-board diagnostic indicators at each station.**

### Features:

- Windows NT/2000 platform
- 32 Infrared PhotoBeams (16 x & 16 y)
- Individual start button at each station
- Automatic 4 level diagnostics
- Maximum Stations 16
- Computer Interface - a single RS232 Serial Port
- User Definable Zones - not factory restricted.
- Post Processing Analysis
- Session Templates
- Individual Runtime Clocks for each station
- User selectable output measures.
- Optional Advanced Graphic Comparators - HotSpots, Playback & OverTime



### Hardware Specifications:

<b>Computer Requirements:</b>	IBM PC compatible w/ Windows NT/2000, Pentium 133 MHz processor, 512 MB RAM, SVGA monitor, 50 MB free hard disk space
<b>Power:</b>	90-240 Vac 50-60 Hz
<b>Overall dimensions:</b>	22.1" (56.13 cm) wide x 22.1" (56.13 cm) long
<b>Subject Field dimensions:</b>	x 15.83" (40.21 cm) high
	16" (40.64 cm) wide x 16" (40.64 cm) long x 15" (38.10 cm) high
<b>Maximum # of stations:</b>	16
<b>PhotoBeams:</b>	Infrared PhotoBeams with 16 x and 16 y resolution
<b>Housing:</b>	Brushed stainless steel
<b>Computer Interface:</b>	A single RS232 serial port, regardless of the size of the system!
<b>Front Panel:</b>	Momentary push button start switch (3sec. lock out.)
	<i>Diagnostic LEDs:</i> 32 green activity LEDs
	4 yellow status LEDs: Switch, rearing, normal mode and float mode

### Measures:

- X Ambulations
- Y Ambulations
- Fine Movements
- Total Breaks
- Time in Zone
- Entries into Zone
- Pokes into Zone
- Distance
- Time @ Rest
- Time Active
- Rearing
- Hole Pokes

### Ordering Information:

- Model HMM100** - MotorMonitor software and control chassis
- Model HSF16x16** - 16" x 16" Beam Open field station
- Model HSF16R** - Open Field Rearing Frame
- Model HSF16HB** - Hole Poke Option (consult factory for details)
- Model HLD2000** - Light/Dark Insert
- Model HVI1000** - Full Visual Isolation Insert
- Model HMM100-OPT** - HotSpots Graphic Comparator
- Model HMM200-OPT** - OverTime Graphic Comparator





## SMARTFRAME™ CAGE RACK SYSTEM

The **SmartFrame** Cage Rack System has been designed with advanced features and ease-of-use as the primary objective. Frames come standard with a two dimensional 4 x 8 beam grid for optimum coverage, not just a few beams in only one dimension. And its high resolution comes at no extra cost! The **SmartFrame** tracks motor activity extremely well for both rat and mouse applications and can serve as a very cost effective Open Field System for mice. It uses the Windows NT/2000 compatible **MotorMonitor** software, providing greater flexibility in analyzing data. The advanced diagnostics use an exclusive 4-level test which runs automatically before each session. Named the **SmartFrame** because of its onboard intelligent circuits, it dramatically enhances validation and diagnostic efforts. Each **SmartFrame** station operates through a single cable from the station to the control chassis, regardless of beam configuration or options. This makes for an exceptionally clean connection setup and eliminates the "rats nest" of cables.

*"A Cage Rack System with higher resolution as a standard!"*



**On-board diagnostic indicators at each station.**

### Features:

- Windows NT/2000 platform
- 12 Infrared PhotoBeams (4 X & 8 Y)
- Individual start button at each station
- Automatic 4 level diagnostics
- Maximum Stations 32
- Computer Interface - a single RS232 Serial Port
- User Definable Zones - not factory restricted
- Post Processing Analysis
- Session Templates
- Individual Runtime Clocks for each station
- User selectable output measures.
- Optional Advanced Graphic Comparators
- HotSpots, Playback & OverTime

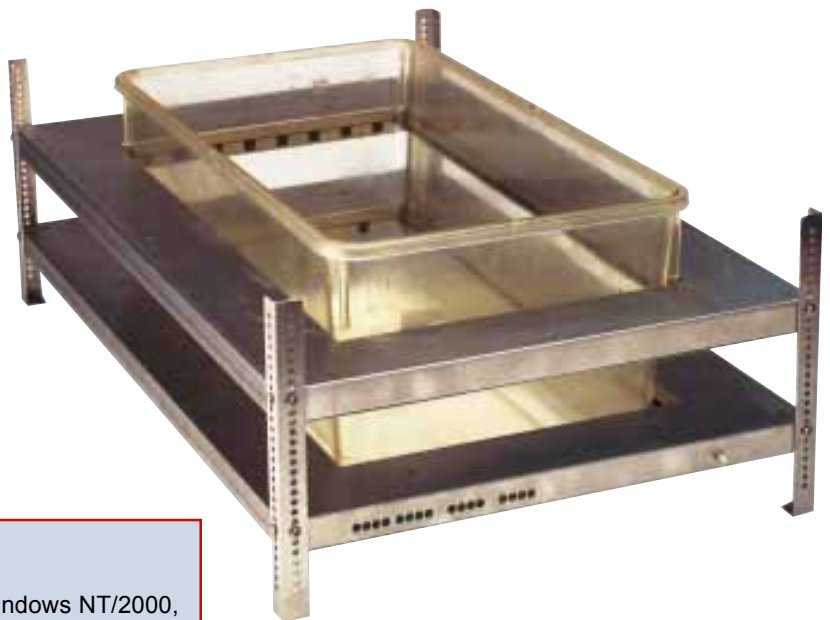

### Hardware Specifications:

**Computer Requirements:** IBM PC compatible with Windows NT/2000, Pentium 133 MHz processor, 512 MB RAM, SVGA monitor, 50 MB of free hard disk space

**Power:** 90-240 Vac 50-60 Hz

**Overall dimensions:** 14.4" (36.58 cm) wide x 23.75" (60.33 cm) long x 0.83" (2.11 cm)

**Internal Frame dimensions:** 9.5" (24.13 cm) wide x 18.0" (45.72 cm) long

**Maximum # of stations:** 32

**PhotoBeams:** Infrared PhotoBeams with 4 X and 8 Y resolution

**Housing:** Brushed stainless steel.

**Computer Interface:** A single RS232 serial port, regardless of the size of the system!

**Front Panel:** Momentary push button start switch (3 second lock out.)

**Diagnostic LEDs:** 12 green activity LEDs  
4 yellow status LEDs: Switch, rearing, normal mode and float mode

### Measures:

- X Ambulations
- Y Ambulations
- Fine Movements
- Total Breaks
- Time in Zone
- Entries into Zone
- Pokes into Zone
- Distance
- Time @ Rest
- Time Active
- Rearing

### Ordering Information:

**Model HMM100** - MotorMonitor software and control chassis

**Model HSF4x8** - Horizontal Frame

**Model HSF4x8R** - Rearing Frame

**Model HLD1000** - Light/Dark Enclosure

**Model HMM100-OPT** - HotSpots Graphic Comparator

**Model HMM200-OPT** - OverTime Graphic Comparator

**Model HMM300-OPT** - Playback Module



## SMARTFRAME™ HIGH DENSITY CAGE RACK SYSTEM

The **SmartFrame** High Density Cage Rack System has been designed with the same advanced features and ease-of-use as our standard Cage Rack System. Frames come standard with a two-dimensional 7 x 15 beam grid for greater resolution; specifically engineered to capture mouse fine-motor activity in an open-field task. The **SmartFrame** tracks motor activity extremely well for both rat and mouse applications and is ideal for paradigms such as place preference for mice. It uses the Windows NT/2000 compatible **MotorMonitor** software common to our activity line, providing greater flexibility in analyzing data. The advanced diagnostics use an exclusive 4-level test which runs automatically before each session. Named the **SmartFrame** because of its onboard intelligent circuits, it dramatically enhances validation and diagnostic efforts. Each **SmartFrame** station operates through a single cable from the station to the control chassis, regardless of beam configuration or options. This makes for an exceptionally clean connection setup and eliminates the "rats nest" of cables.

### On-board diagnostic indicators at each station

#### Features:

- Windows NT/2000 platform
- 22 Infrared PhotoBeams (7 x & 15 y)
- Individual start button at each station
- Automatic 4 level diagnostics
- Maximum Stations 24
- Computer Interface - a single RS232 Serial Port
- User Definable Zones - not factory restricted
- Post Processing Analysis
- Session Templates
- Individual Runtime Clocks for each station
- User selectable output measures.
- Optional Advanced Graphic Comparators  
HotSpots , Playback & OverTime

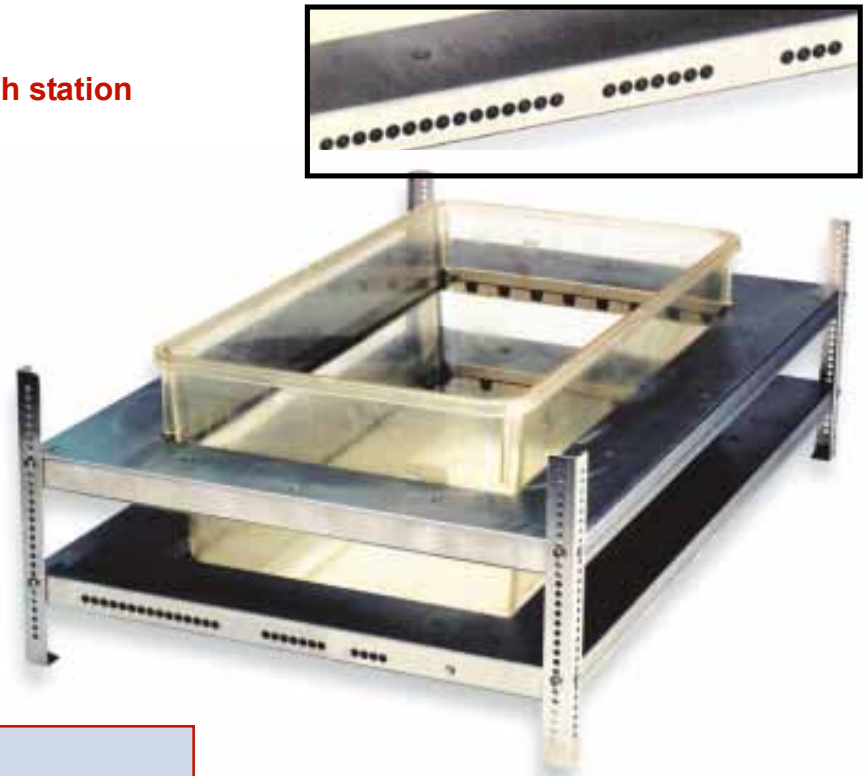

#### Hardware Specifications:

**Computer Requirements:** IBM PC compatible with Windows NT/2000, Pentium 133 MHz processor, 512 MB RAM, SVGA monitor, 50MB of free hard disk space.

**Power:** 90-240 Vac 50-60 Hz

**Overall dimensions:** 14.4" (36.58 cm) wide x 23.75" (60.33 cm) long x 0.83" (2.11 cm)

**Internal Frame dimensions:** 9.5" (24.13 cm) wide x 18.0" (45.72 cm) long

**Maximum # of stations:** 24

**PhotoBeams:** Infrared PhotoBeams with 7 x and 15 y resolution.

**Housing:** Brushed stainless steel.

**Computer Interface:** A single RS232 serial port, regardless of the size of the system!

**Front Panel:** Momentary push button start switch (3 second lock out.) Diagnostic LEDs: 22 green activity LEDs. 4 yellow status LEDs: Switch, rearing, normal mode and float mode

#### Measures:

- X Ambulations
- Y Ambulations
- Fine Movements
- Total Breaks
- Time in Zone
- Entries into Zone
- Pokes into Zone
- Distance
- Time @ Rest
- Time Active
- Rearing

#### Ordering Information:

**Model HMM100** - MotorMonitor software and control chassis

**Model HSF7x15** - 7x15 Beam High Density Cage Rack Station

**Model HSFCRHDR** - High Density Rearing Frame

**Model HLD1000** - Light/Dark Enclosure

**Model HPP2000** - Place Preference Insert

**Model HMM100-OPT** - HotSpots Graphic Comparator

**Model HMM200-OPT** - OverTime Graphic Comparator

**Model HMM300-OPT** - Playback Module

# Anti-Depression/Anxiety

- *Cued & Contextual Conditioning*
- *Elevated Plus Maze*
- *Forced Swim*
- *Tail Suspension*
- *Helplessness Chamber*



## CUED & CONTEXTUAL FEAR CONDITIONING SYSTEMS

Our Cued & Contextual Fear Conditioning System is actually made up from our **MotorMonitor** High Density Cage Rack System and a set of options which enable the user to administer a variety of stimuli including shock, tone, and cue lights. During the training day, a set of simple commands pairs the shock with the cues and invokes a freezing behavior from the subject. On the following day the subject is tested without the foot shock to see if the subject has “remembered” the pairing.

The system comes with our new 7 x 15 beam High Density Cage Rack System which has been designed especially for mice.

Additionally supplied is our new fully programmable shocker which has the industry’s first grid leak detection circuit for ensuring proper shock administration.



### Features:

- Windows® NT/2000/XP platform
- 22 Infrared PhotoBeams (7 X & 15 Y)
- Individual start button at each station
- Automatic 4 level diagnostics
- Maximum Stations 32
- Computer Interface - a single RS232 Serial Port
- User Definable Zones - not factory restricted.
- Post Processing Analysis
- Session Templates
- Individual Runtime Clocks for each station
- User selectable output measures.
- Optional Advanced Graphic Comparators - HotSpots, Playback & OverTime

*“Specially Designed for Mice”*



## CUED & CONTEXTUAL FEAR CONDITIONING SYSTEMS (CONTINUED)

### Measures:

- X Ambulations
- Y Ambulations
- Fine Movements
- Total Breaks
- Time in Zone
- Entries into Zone
- Pokes into Zone
- Distance
- Time @ Rest
- Time Active
- Rearing



### Ordering Information:

**Model HMM100** - MotorMonitor software and control chassis

**Model HSF7x15** - 7x15 Beam High Density Cage Rack Station

**Model HFC1000** - Fear Conditioning Option

### Hardware Specifications:

**Computer Requirements:** IBM PC compatible with Windows NT/2000, Pentium 133 Mhz processor, 512 MB RAM, SVGA monitor, 50 MB free hard disk space.

**Power:** 90-240 Vac 50-60 Hz

**Overall Dimensions:** 14.4" (36.58 cm) wide x 23.75" (60.33 cm) long x 0.83" (2.11 cm) high.

**Internal Frame dimensions:** 9.5" (24.13 cm) wide x 18.0" (45.72 cm) long.

**Maximum number of stations:** 32

**PhotoBeams:** Infrared PhotoBeams with 7 x and 15 y resolution.

**Housing:** Brushed stainless steel.

**Computer Interface:** a single RS232 serial port, regardless of the size of the system!

**Frame Front Panel:** Momentary push button start switch (3 second lock out.)

**Diagnostic LEDs:** 12 green activity LEDs. 4 yellow status LEDs: Switch, rearing, normal mode and float mode.



## AUTOMATED ELEVATED PLUS MAZE SYSTEMS

Our new mazes have higher resolution and specially created measures which enhance the ability to quantify anxiety. For example, with beams mounted on the edge of the open arms we capture the subject hanging it's head over the edge. Going out on the cliff is one thing, hanging over the edge of it is another. And the high resolution can separate arms into multiple zones. These multiple zones report how far an animal retreats from the intersection into closed arms and how far it dares into the open arms. A truly new ability in quantifying the animals emotionality .

As with all our activity systems, the plus maze systems have been designed with advanced features and ease of use in mind. All

**PhotoBeams** are mounted on circuit boards for easy replacement and the system uses the Windows NT/2000 compatible **MotorMonitor** software common throughout our activity line.

**MotorMonitor's** post analysis software provides greater flexibility in analyzing and re-analyzing data based on different parameters. The new measure **Pokes Into Zone** was specially designed for plus mazes; it differentiates between an animals complete entry into a zone and when it conducts only a small head poke into a zone. The advanced diagnostics use an exclusive 4-level test which runs automatically before each session. Each maze operates through a single cable making for an exceptionally clean connection setup by eliminating the "rats nest" of cables of the past. Because of it's unique design, it is possible to run 2 or more mazes simultaneously, thereby increasing throughput!



*“High density beams provide higher quality measures from our all new plus mazes!”*

### Measures:

- X Ambulations
- Y Ambulations
- Fine Movements
- Total Breaks
- Time in Zone
- Entries into Zone
- Pokes into Zones
- Distance
- Time at Rest
- Time Active

### Features:

- Windows® NT/2000 platform
- 36 Infrared PhotoBeams
- Individual start button at each station
- Automatic 4 level diagnostics
- Maximum Stations 8
- Post Processing Analysis
- Computer Interface - a single RS232 Serial Port
- Session Templates
- User Definable Zones - not factory restricted.
- Selectable output measures
- Individual Runtime Clocks for each station
- Optional Advanced Graphic Comparators - HotSpots, Playback & OverTime



## **AUTOMATED ELEVATED PLUS MAZE SYSTEMS (continued)**

### **Hardware Specifications**

#### **Automated Maze Systems:**

**Computer Requirements:** IBM PC compatible with Windows NT/2000, Pentium 133 MHz processor, 512MB RAM, SVGA monitor, 50 MB free hard disk space.

**Power:** 90-240 Vac 50-60 Hz

**Maximum number of stations:** 8

**PhotoBeams:** 36 Infrared PhotoBeams

**Computer Interface:** A single RS232 serial port, regardless of the size of the system!

#### **Automated and Manual Maze Systems:**

**Rat Maze Overall dimensions:** 44" (111.76 cm) wide x 44" (111.76 cm) deep x 33.5" (85.09 cm) tall

**Rat arena dimensions:** each arm is 4.25" (107.95 cm) wide and 19.75" (50.17 cm) long, intersection is 4.25" (10.80 cm) x 4.25" (10.80 cm), closed walls are 15.75" (40.01 cm) high.

**Mouse Maze Overall dimensions:** 30.5" (77.47 cm) wide by 30.5" (77.47 cm) deep by 30.5" (77.47 cm) tall

**Mouse arena dimensions:** each arm is 2" (5.08 cm) wide and 14" (35.56 cm) long, intersection is 2" (5.08cm) x 2" (5.08 cm), closed walls are 6" (15.24 cm) high.

### **Ordering Information:**

#### **Automated Maze Systems:**

Model HMM100 - MotorMonitor software and control chassis

Model HEMP1001 - Automated Rat station including maze and all hardware and cables required (with PhotoBeams)

Model HEMP2001 - Automated Mouse station including maze and all hardware and cables required (with PhotoBeams)

#### **Optional Software:**

Model HMM100-OPT - HotSpots Graphic Comparator

Model HMM200-OPT - OverTime Graphic Comparator

Model HMM300-OPT - Playback Module

#### **Manual Maze Systems:**

Model HEMP1000B - Elevated Plus Maze, Manual – Rat (without photo beams)

Model HEMP2000B - Elevated Plus Maze, Manual – Mouse (without photo beams)

Use these elevated plus mazes for manual or observer scored test sessions. Sessions may be scored in real time or video taped for later scoring. These mazes may also be used with video tracking systems offered by other companies and soon to be offered by Lafayette Instrument Co.



## AUTOMATED FORCED SWIM TEST

This newly designed system uses our popular **MotorMonitor** control chassis and software to capture the subjects swimming activity and readily demonstrates when the animal begins to give up its attempt for escape. The software makes an easy task of reduction and entire study into one .csv (comma separated values) file. This file is then used for quick transfer into a spreadsheet or other statistical program. Animals are placed in the tank typically for 15 minutes and monitored for when they reach a "despair" condition. This condition is indicated by the lack of any attempt by the animal to swim, climb, or dive in the tank and typically occurs around 10 minutes on the first day. On the second day, the animal is tested for a 5 minute session. The animals tend to "give up" at around 2 minutes, thus demonstrating the "learned helplessness" model of depression. A drug significantly extending this 2 minute time would presumably indicate an improved condition.

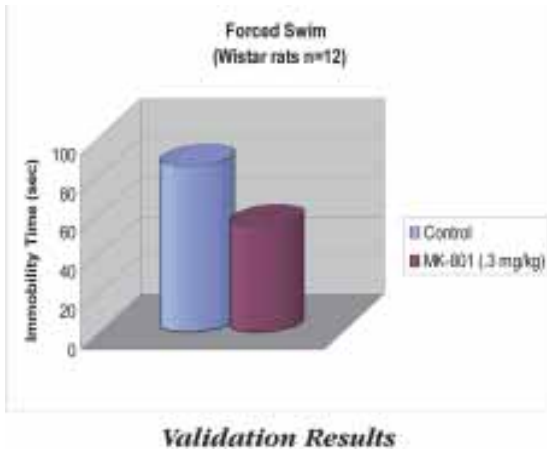

### Features:

- Windows® NT/2000/XP platform
- 8 Infrared PhotoBeams (4 X & 4 Y)
- Individual start button at each station
- Automatic 4 level diagnostics
- Maximum Stations 32
- Computer Interface - a single RS232 Serial Port
- User Definable Zones - not factory restricted.
- Post Processing Analysis
- Session Templates
- Individual Runtime Clocks for each station
- User selectable output measures.
- Optional Advanced Graphic Comparators - HotSpots, Playback, & OverTime

### Measures:

- X Ambulations
- Y Ambulations
- Fine Movements
- Total Breaks
- Time in Zone
- Entries into Zone
- Distance
- Time @ Rest
- Time Active

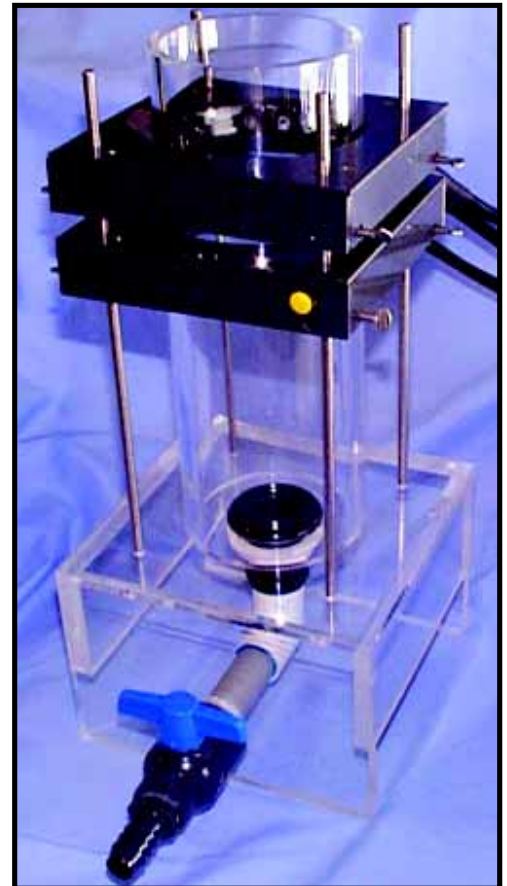

HFS100 Forced Swim Test

### Hardware Specifications:

Hardware specifications as per **MotorMonitor** with the following exceptions:

**Overall Mouse Enclosure Dimensions:** 8" x 8" (20.32 x 20.32 cm) base, 4.5" (11.43 cm) OSD tube, 12.5" (31.75 cm) height.

**Overall Rat Enclosure Dimensions:** 10" x 10" (25.4 x 25.4 cm) base, 8" (20.32 cm) OSD tube, 17" (43.18 cm) height.

**Maximum number of stations:** 32

**PhotoBeams:** Infrared PhotoBeams with 4 X and 4 Y resolution

### Ordering Information:

Model HMM100 - MotorMonitor software and control chassis

Model HFS1000 - Forced Swim Option for Rats

Model HFS2000 - Forced Swim Option for Mice

Model HMM100-OPT - HotSpots Graphic Comparator

Model HMM200-OPT - OverTime Graphic Comparator

Model HMM300-OPT - Playback Module



## TAIL SUSPENSION SYSTEM HTS100

### An Antidepressant Model for Mice

The Tail Suspension was developed in the late 1980's as an alternative to the "behavioral despair" or swim test where the animal is forced to swim in an arena with no possibility for escape. Similarly in this method, the animal is suspended from its tail for a 6 minute test (user definable) and cannot "escape". During the test the system records the number of times (events) each subject enters into an escape behavior (struggling episodes), the duration of the event and the average strength of each event.

- Windows® NT/2000/XP based Software
- Fully user-defined settings
- Post analysis
- Up to 4 subjects
- All measures reported in both session totals and intervals

This screen display represents the actual raw data as collected. The recording is a continuous collection of samples which are analyzed post session. This allows the user to re-set any parameters and re-process the data files at any future time.

This next screen display demonstrates the filtered data from a typical session. Notice that the activity now appears to be in blocks or episodes.

### Features:

- Windows® NT/2000/XP platform
- Output files easily exported to spreadsheets or other statistical programs
- 3 year comprehensive warranty
- Run up to 4 units simultaneously

### Hardware Specifications:

- **Event Counter** - Increments each time the subjects force exceeds a predefined value
- **Time Tally** - The accumulated time during each interval for all events
- **Force Tally** - The average strength or amplitude for each event
- **Overall Dimensions:** 7.5" (19.05 cm) wide x 12" (30.48 cm) deep x 13" (33.02 cm) high

### Ordering Information:

Model HTS100 - Tail Suspension System for Rodents (software and control chassis) - Not a MotorMonitor Product  
Model HTS1001 - Tail Suspension Station

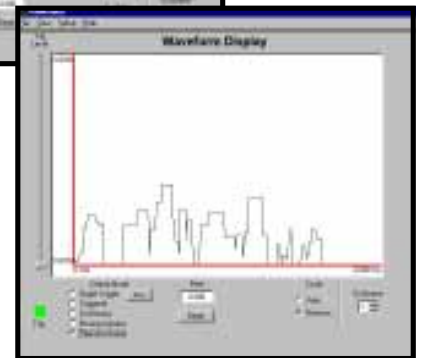
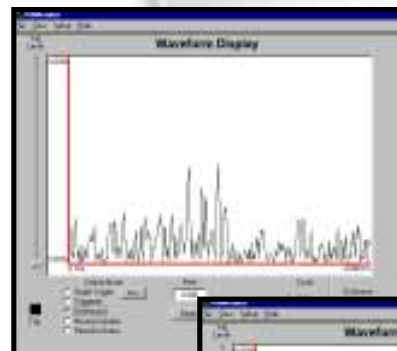



## Helplessness

### Rat Helplessness Chamber Model 80010

The Rat Helplessness Chamber Model 80010 allows researchers to test for failure to escape aversive stimulus. The helplessness chamber comes with a revolution count selector switch to easily adjust task difficulty. The rat is placed in the chamber which has a 12-rung wheel located in the front of the rat. The rat's tail is immobilized so that tail-shocks can be administered.

#### Escapable:

The helplessness chamber wheel turn output is read by the computer through appropriate interfacing. ABET or other suitable scheduling software is used to program the desired behavioral escape response. Turning the wheel to the pre-programmed number of revolutions will turn off the shock generator. Rats will learn quickly to turn the wheel to avoid the tail-shock.

#### Inescapable:

With two helplessness chambers one rat is the control and a second rat is yoked through the interfacing and scheduling software. Both rats have electrodes on their tails but the control rat is not connected to the shock generator. The rat in the yoked chamber has no control over the delivery of tail-shock and is thus in an inescapable paradigm. The rat in the control chamber will not receive the tail-shock but will experience behavioral contingencies. The yoked rat will receive all the tail-shocks that the control rat allows.



#### Options:

- Model 88500 - ABET Software & Starter Kit - for operant control and monitoring of wheel turns
- Model 58006 - Constant Current Shocker (1mA max)
- Model 82400SS - Master Shock Supply (5mA max)
- Model 82415IS - Squarewave Stimulator (single or train pulse)

#### Technical Specifications:

<b>Overall Dimensions:</b>	19.0" x 9.0" x 7.3"
<b>Chamber Dimensions:</b>	5.4" x 4.4" x 7.8"
<b>Counts per Revolution:</b>	1, 2, 4, 8, 16, 32
<b>Chamber Material:</b>	Floor & Top - 0.062" Aluminum Side Walls - 0.125" Clear Polycarbonate Tail Support - UHMW Polyethylene Wheel - Aluminum Rungs, Polycarbonate Side Walls
<b>Power Requirements:</b>	28 VDC, 35mA
<b>Wheel Turn Output:</b>	Open-collector, max I-sink 5mA (Active low)

# Learning & Memory Systems

- *Active/Passive Avoidance*
- *Pathfinder Mazes*
- *Hole Board*  
(see *Photobeam Activity*)





## LEARNING & MEMORY SYSTEM MODEL HLM100

Our Learning and Memory System sets the industry standard for versatility and design. With the ability to perform a multitude of paradigms, this system can easily adapt to your changing research needs. With an impressive set of design features found on no other system currently available, the HLM100 provides the level of confidence needed for the most demanding laboratory environments.

### Impressive Paradigm List

- Active Avoidance
- Single Trial Passive Avoidance
- Multi-trial Passive Avoidance
- Trials to Criterion\*
- Step Down Avoidance\*
- Cued/Contextual Fear Conditioning\*
- Three Compartment Place Preference for Mice\*
- Freeze Monitoring\*
- Motor Activity Monitoring\*

\* Under Development



### Learning & Memory Features & Functions

#### Stainless Steel Animal Compartments & Electronics-Free Grid Floor

Designed with the user in mind, there are no electronics in the animal compartments. The entire unit can be removed and placed in a cagewash or autoclave for effortless cleaning!

#### Shock

This innovation finally provides a solution to truncated shock. When animals receive shock they will inevitably discharge much fluid and excrement. When this occurs there is frequently a resulting coating that will develop between shock grids. This coating can easily truncate some of the shock away from the subject, which of course will confound the data. To solve this problem we have built a unique testing circuit that helps you test for the condition and resolve it prior to running studies.

#### LED Position Indicators

Designed into our system are 16 position indicator LEDs. This feature makes monitoring subject position effortless. The LEDs are bright and easily readable from a distance.

#### Modular Service Pack

Virtually all of the Learning & Memory Station's controls and electronics are contained in the service pack.





## LEARNING & MEMORY SYSTEM MODEL HLM100 (continued)

### Fully Ventilated Enclosure

### Optional Video Cameras

Monitor subject behavior without disturbing the session!  
An excellent tool for validation. Keep a constant eye on animal behavior or record sessions for later playback.

### Variable Intensity House Lights

This LED array provides enough output to be used for an alternate UCS.

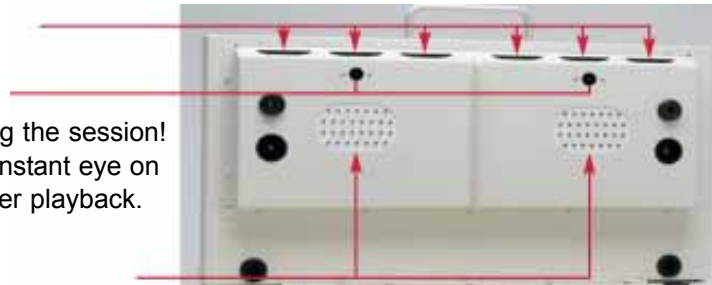

### Color Programmable Walls

Single Trial Passive Avoidance has long had the problem of First Trial Crossing Failure. The failure of the subject to cross to the dark side on its first exposure to the enclosure greatly puts into question the use of that animal in the data. By using these programmable wall colors and other Hamilton-Kinder unique enclosure designs you be able reduce the impact of this common problem.

### Ultra-Quiet Programmable Gate

### Optional Air UCS

Use as an alternative to shock:

Air Pressure Adjust

Air Pressure gauge

Quick disconnect air hose connections



### Hardware Specifications:

<b>Computer Requirements:</b>	Windows® NT/2000/XP
<b>Maximum Stations:</b>	8
<b>Power Input:</b>	100-240 Vac ~, 6.0A, 47-63 Hz
<b>Overall Footprint:</b>	<i>Depth:</i> 15.7" (39.88 cm) <i>Width:</i> 27.25" (69.22 cm) <i>Height:</i> 14.06" (35.71 cm)
<b>Subject Arena for each side:</b>	<i>Depth:</i> 8" (20.32 cm) <i>Width:</i> 10" (25.4 cm) <i>Height:</i> 8" (20.32 cm)
<b>Construction:</b>	Powder-Coated Steel
<b>Grid Floors:</b>	Stainless Steel
<b>Foot Shock:</b>	8 Output & Fully Programmable 0-5ma
<b>Sensing:</b>	8 Photo Beams per side
<b>Auto-Gate</b>	
<b>Weight:</b>	40 lbs (18.14 kg)

### Excellent for Both Passive & Active Tests

The software in our MotorMonitor system has been so well received that we have used the same approach in developing our new Learning & Memory system. Easy to use input screens provide the user with the features and flexibility to get the job done.

### Ordering Information:

- Model HLM100-4 - Learning & Memory System - software and 4 system control chassis
- Model HLM100-8 - Learning & Memory System - software and 8 system control chassis
- Model HLM1000 - Learning & Memory Station
- Model HLM100SP - Service Pack
- Model HLMG-R - Learning & Memory Grid - Rat
- Model HLMG-M - Learning & Memory Grid - Mouse
- Model HAGATE2 - Auto-Gate





## PATHFINDER RADIAL ARM MAZE

### Manual Pathfinder Maze System Model 89001A

- Arena Center Enclosure Kit w/ Doors, Clear Model 89117**
- Arena Center Enclosure Kit w/ Doors, Red Model 89117R**
- Wall Kit Sides and Ends for all Runways, Clear Model 89116**
- Wall Kit Sides and Ends for all Runways, Red Model 89116R**
- Complete Maze Insert Kit, Clear Model 89115**
- Complete Maze Insert Kit, Red Model 89115R**

R = Red Polycarbonate Walls

Also available in Smoked Polycarbonate designated by the model number extension "S".

Both the manual and motorized versions of the Pathfinder Maze System provide an amazing advancement in controlled learning and memory devices. This maze system allows for control of visual, auditory, and olfactory cues. Less interference leads to quicker learning. The Pathfinder controls these variables through standard features, such as:

1. Control bridges or doors (optional) with 20 feet of separation between the operator and the maze
2. Washable scent/stain-resistant finishes eliminate unwanted stimuli
3. Aluminum arena and runways provide a sturdy durable platform that will not absorb odors
4. EZ-Turn design lets you rotate the entire maze 359 degrees to control spatial cues without disconnecting the control cables or wires
5. The manual Quiet-Lift bridges and doors (optional) add an extra degree of auditory cue reduction when required. Refer to the back of this flyer for an optional arena kit as well as optional walls and inserts.

Model 89001A  
(shown with optional Arena Kit - Model 89117)



Control Box (for Model 89001A)

### Technical Specifications:

Manufactured Materials: Polycarbonate Walls  
Polycarbonate Guillotine Doors  
High-Strength, Lightweight Aluminum

Overall Weight:	75lbs
Overall Diameter:	70.0"
Overall Height:	35.0"
Min/Max Diameter of the Arena:	13.75/15.0"

Remote Control Unit:	
Length	10.75"
Height	8.0"
Width	4.5"
Can be Operated up to 20'	

Arms:	
Length of an Arm	27.5"
Outer Width of an Arm	4.12"
Inner Width of an Arm	3.87"
Height of an Arm Side Channel	0.8"
Height of the Standard Arm Walls	8.0"

Doors:	
Height of the Arena Guillotine Doors and Columns	13.75"
Clearance Width Through a Guillotine Door	3.87"
Clearance Height Through a Guillotine Door	5.0"

### Basic Pathfinder Maze System (Motorized) Model 89001B

In the manual model above the bridges or optional doors are raised and lowered with mechanical levers connected via flexible metal control cables. In this unit small electric motors are added to the base of the maze that can be connected to either the door or bridge mechanism and the mechanical levers are replaced by an electrical switch box and standard DB-25 Cable. Connections are also provided for optional interface control.



Model 89001B  
(shown with optional Arena Kit - Model 89117)



## Pathfinder Flex Contain System

Select from a number of wall, arena, and inset kits to provide the exact configuration and level of animal containment required for your research. Each is available in clear, smoked, or red tinted polycarbonate to convert the open system above to a completely enclosed system if required. When using the Arena Kit, the polycarbonate doors are connected to the same linkage used to operate the bridges (manual or motorized) while the bridges are locked in the up position. With the versatility of the following components, the maze can be configured as a T, Y and Plus maze as well as a straight 70" long runway.

MAZE INSERT KIT CONFIGURATION

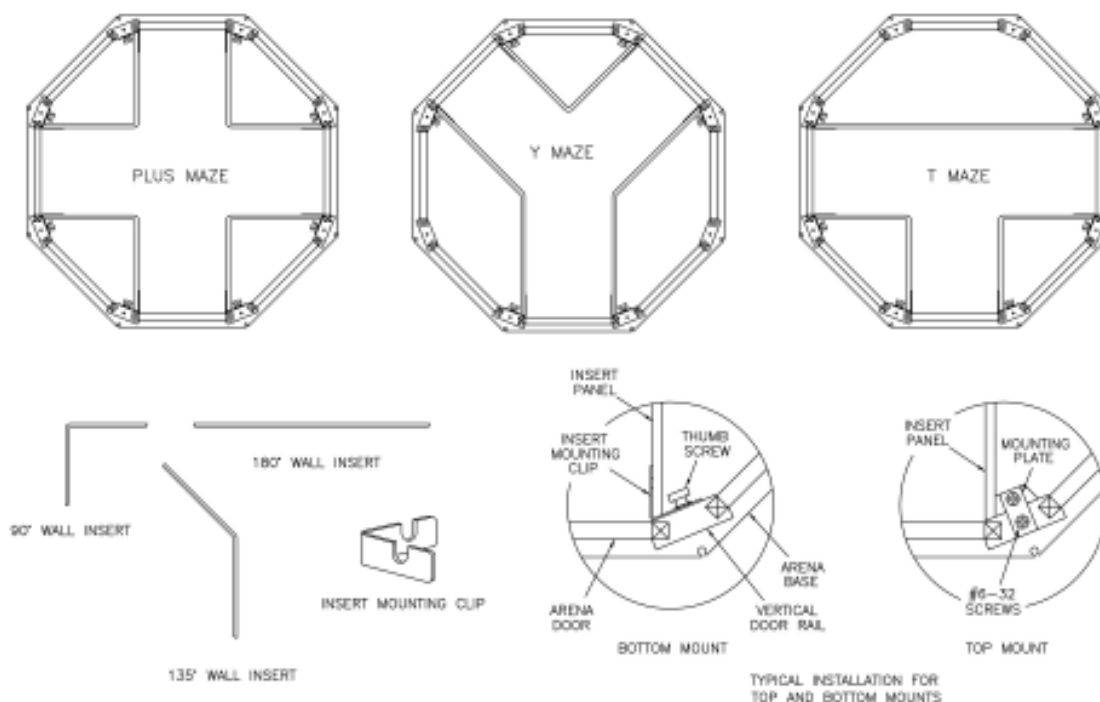

### To Order Clear Polycarbonate Kits and Inserts Specify:

- Arena Kit Center Enclosure w/ Doors - order Model 89117
- Wall Kit Sides and Ends for All Runways - order Model 89116
- Complete Insert Kit (4 @ 90°, 2 @ 135°, 2 straight) - order Model 89115

### Individual Inserts:

- "T" Maze Configuration Requires:
  - (2) 90° Wall Inserts - order Model 89100
  - (1) Straight Wall Inserts - order Model 89105
- "Y" Maze Configuration Requires:
  - (1) 90° Wall Inserts - order Model 89100
  - (2) 135° Wall Inserts - order Model 89110
- "Plus" Maze Configuration Requires:
  - (4) 90° Wall Inserts - order Model 89100
- Runway Configuration Requires:
  - (2) Straight Wall Inserts - order Model 89105

\* To order Red Tinted (transparent) Polycarbonate, simply add an "R" to the above model numbers - example: Model 89117R, Model 89116R, etc.

\*\* To Order Smoked Polycarbonate add an "S" to the above model numbers - example: Model 89117S, Model 89116S, etc.

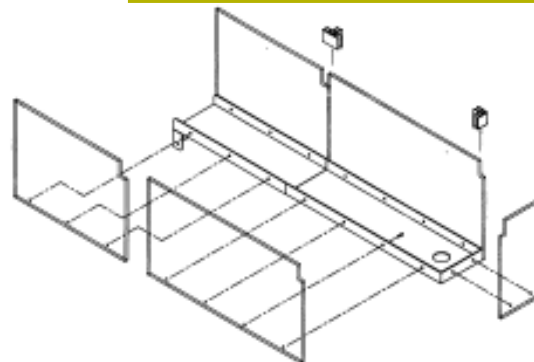

# Startle Systems

- *StartleMonitor Systems*



## STARTLEMONITOR™ SYSTEM

When we began development of our **StartleMonitor** system we were determined to set a new standard for performance, reliability and ease of use. After several years of extensive research and development we have finally reached that goal. Our design staff of 4 engineers used their combined experience of 40 years in behavior instrumentation to create this rugged new system. And it is with great pride and excitement we offer the Startle Monitor system for your consideration. Superior acoustic design helps to eliminate system induced variability. We've designed our system with high precision circuitry; providing +/- 1 dB accuracy at all points of the scale (57-120 dB) and from chamber to chamber! Our cabinets have the highest sound attenuation available on the market, -35dB. Older systems commonly use tubes for restraint. It has been well established that tubes induce stress and stress affects startle. In response to this problem we designed a new restraint mechanism that greatly reduces the stress on the subject. Call us for details.

### StartleMonitor - The best choice for:

#### Transgenic & Mutant mouse studies!

The Startle Monitor system has been specially designed for use with transgenic mice. We've incorporated critical features into the system such as ambient vibration immunity and extremely high sensitivity for the small responses of mice.

#### Pre-pulse Inhibition

The ability to run pre-pulse inhibition trials is already a part of the system. Simple Windows commands help you easily create these trials.

#### Cross Modal Pre-pulse Inhibition

#### Gap Detection

Similar to pre-pulse inhibition, but with a decrease or absence of sound. This mode of testing is also built-in.

#### Standard Acoustic Trials

Exceptional acoustic characteristics for classic startle reflex.

#### Fear Potentiated Options

All components needed for a complete fear potentiated operation.

#### Habituation Trials

#### Tactile (air puff) Startle Reflex

#### Latin Square Presentation of Trials

### Helping to Eliminate System Induced Variability

Startle research has long had a reputation for high subject-to-subject variability. Acoustic startle responses are tied directly to the accuracy of the noise stimulus and the quality of the ambient noise control. We've designed our system with high precision circuitry, providing +/- 1 dB accuracy at all points of the scale (57-120 dB) and from chamber to chamber! Startle will always have variability because of the nature of startle response. However, we set out to eliminate known system weaknesses which have caused unnecessary variability.



*Startle Monitor Key Features  
Superior Acoustic Design!*





## STARTLEMONITOR™ SYSTEM KEY FEATURES:

*Superior Acoustic Design!*

### 35 Decibels of Attenuation!

Our cabinets have the highest sound attenuation available on the market. The closest competition provides only 22-25 dB. Recall that each decibel represents a multiple of 10. Therefore, an increase of more than 10 decibels is very significant.

### No Acoustic Calibration or Strange Tables to Create or Use

Simple and direct! Because of the outstanding attenuation, you are able to use noise levels down to 57 dB! You are no longer limited to 65 dB as a lower limit. And our system is factory calibrated so all you do is enter the desired level. No calibration tables to create for each station nor do you use an arbitrary number table as with some systems. You simply enter the level you want and that's it!

### Microsoft® Windows® NT/2000 Based System

Like all of our products, the Startle Monitor system is Windows NT/2000 compatible. There is no PC card to install in your computer. All that is required is a serial cable between your computer and the control chassis. The control chassis can handle up to eight stations using a single PC! Like all of our products, the Startle Monitor system is Windows NT/2000 compatible. There is no PC card to install in your computer. All that is required is a serial cable between your computer and the control chassis. The control chassis can handle up to eight stations using a single PC!

### Stress Affects Behavior & Tubes Induce Stress!

Older systems use a design placing animals into tubes. And tubes have long been known to create stress. Our new restraint design contains the subject consistently over the sensing transducer while still providing an ample sensation of freedom of movement. The key is in the adjustable ceiling which allows the subject increased headroom without permitting ambulations.

Startle Monitor Key Features New restraint design removes stress induced by older tube method:

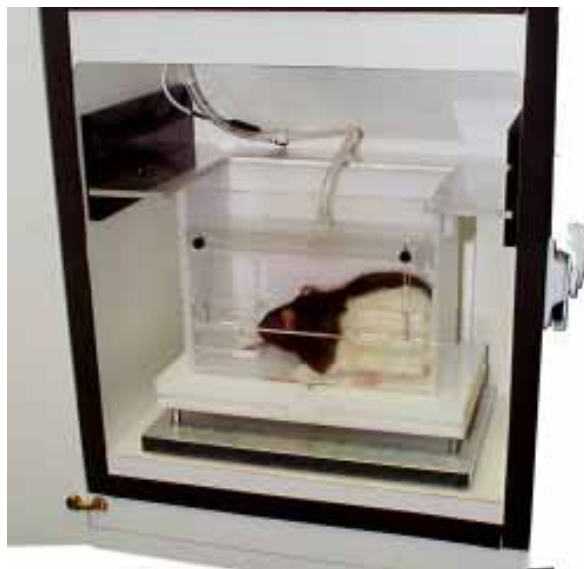

### Durability

The feet on the transducer assembly have been moved to a special anchor plate. And because we use a piezo disk and not a delicate load cell, the assembly is rugged and *not* easily affected by user handling.

### Calibrated in Newtons, not Arbitrary Units!

A single pulse calibrator allows your data to be reported in milli Newtons. Now you can have confidence about comparing studies. There is no longer a concern over the systems original setting. Additionally, the high stability of the system helps reduce the number of times needed to check calibration.

### Higher Throughput With Less Cleaning Time

We listened to the comments of experienced scientists and research assistants who've suffered for years with cleaning problems. Active labs report spending over an hour just cleaning large systems. Our unique refuse tray is built right into the sensing tray to gather and contain waste. For cleaning, you simply remove the sensing plate, rinse it and you're ready to proceed with the next session. We want you performing studies, not cleaning refuse.





## STARTLEMONITOR™ SYSTEM KEY FEATURES:

### Easy to Use Windows NT/2000 Based Software

The **StartleMonitor** software has been modeled after our popular **MotorMonitor** program, with concise yet flexible input screens. As shown here we've created a single input screen that will do most of your work. You can input session parameters, order your trial list, input subject information, edit trials, edit sessions, and finally run any desired session you chose all from this screen!

### Simple Data Reduction!

First select the file to reduce and then just give it an output file name. You're done!

### Compact Cabinet to Help Conserve Your Lab Space

We realize how precious lab space can be so we made our cabinet design the smallest in the industry. You can place twice as many cabinets in the same space and still have a system that outperforms them all!

### Options:

#### Potentiated Startle Reflex Kit

The optional Potentiated Startle Reflex kit adds foot shock and a conditioning stimulus for potentiated startle studies. The conditioning stimulus can be acoustic, light, tactile or user-supplied.

#### Tactile Kit

The Tactile Kit provides air puff stimulation to rats and mice.

### Ordering Information:

- Model HSM100 - StartleMonitor System (software and control chassis)
- Model HSM1001 - Startle Station
- Model HSM2001 - Rat insert and sensing plate
- Model HSM2002 - Mouse insert and sensing plate
- Model HSM2003 - Guinea Pig insert and sensing plate
- Model HSMG-R - Fear Potentiated accessories for rats (not including shocker)
- Model HSMG-M - Fear Potentiated accessories for mice (not including shocker)
- Model HSMSCK - Programmable Animal Shocker (scrambled output)
- Model HSMTAC - Tactile Option
- Model HSMCAL - Newton Impulse Calibrator
- Model HSMSPL - Sound Meter

*New restraint design removes stress induced by older tube method!*

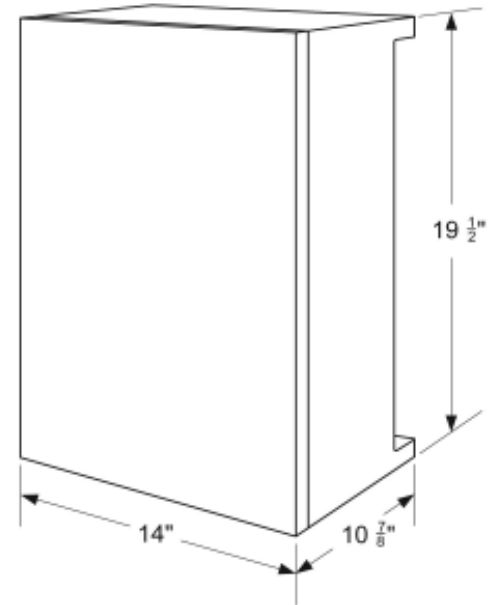

### Hardware Specifications:

#### Acoustic Performance:

- Full range White Noise . - 57 to 120 dB +/- 1 dB
- Chamber to Chamber variation +/- 1 dB
- Cabinet Isolation . . . . . -35 dB +/- 2 dB

#### Response Performance:

- Piezo Transducer Calibrated and Reported in Newtons +/- 1% full scale

#### Control Circuitry & Software:

- Independent Control Chassis (no pc card to install)
- Simple RS232 Serial communication
- Station connection - via a single parallel cable
- Windows NT/2000 Platform

#### Physical characteristics:

- Compact Cabinet Design: 14" (35.56 cm) wide x 10.875" (27.62 cm) deep by 19.5" (49.53 cm) high
- Weight: 35 lbs (15.88 kg)
- Cabinet built from High Quality Laminate and MDF

#### Animal Restrainers:

- Built in refuse system
- Stress free design (no tubes)
- Durable "footless" design sensing platform

# Feeding Analysis System





## FEEDING ANALYSIS SYSTEM

### Modular Microstructural Feeding & Drinking Analysis & Activity Monitoring for Rodents Model 80350

A modular system for rats capable of a wide range of sensitivity in recording weight of food consumed and timed feeding bouts. For research of feeding disorders and ethological measures of behaviour.

The Campden Microstructural Feeding System is modular in two respects. Firstly, it can be tailored to be sensitive to the feeding of different rodents and secondly its modularity extends to how the hardware is configured.

The feeding/drinking station, consisting of the feed hopper or bottle, load cell and associated electronics can be fitted to any of our rodent chambers of appropriate size. Load cells of a range of sensitivities are available to whatever accuracy of weight is desired, it should also be remembered however that the more sensitive the load cell is the less total load it is able to sustain. Thus for prolonged experiments at high sensitivities it may be necessary to refill the food hopper or bottle either manually or by a mechanical system. The aperture into which the animal inserts its head to gain access to the powdered diet or drinking spout can be varied by a slide to account for different sizes of animal and cannulated animals. A separate catch tray extends 25mm into the cage, under the grid floor in order to catch any spillage when the animal withdraws from the feeding hole. The presence of the animal at the feeding/drinking station is detected by infra red beams and measurements are then taken immediately before and after a 'meal'.

The software, a menu driven Windows® –based package allows the user to define the minimum size of a 'meal' and the minimum time between meals at the outset. Animal activity is reported concurrently and presented onto an Excel spreadsheet. Up to 16 chambers can be run from one Interface Box and one Acquisition Card. For 17 to 32 chambers two Interface boxes and two Acquisition cards are required.

#### PC requirements are IBM compatible PC with the following features:

- Processor:** 2 GHz Pentium IV PC or equivalent
- Operating System:** Windows® 98, NT/2000, or XP
- Ports:** one free PCI slot
- Disk:** 500MB free hard disk space for the application
- RAM Requirement:** 126MB

#### The modular components of the Model 80350 Microstructural Feeding / Drinking Analysis System are described as follows:

- Model 80350FS - Feeding Station
- Model 80350IBC - Interface Box and PC Acquisition Card
- Model 80350S16 - Software for 1-16 chambers
- Model 80350S32 - Software for 1-32 chambers
- Model 80350SC - Small chamber
- Model 80350LC - Large Chamber





- *Mouse Reaching Chamber*
- *Rat & Mouse Motility StairCase*

# Motility

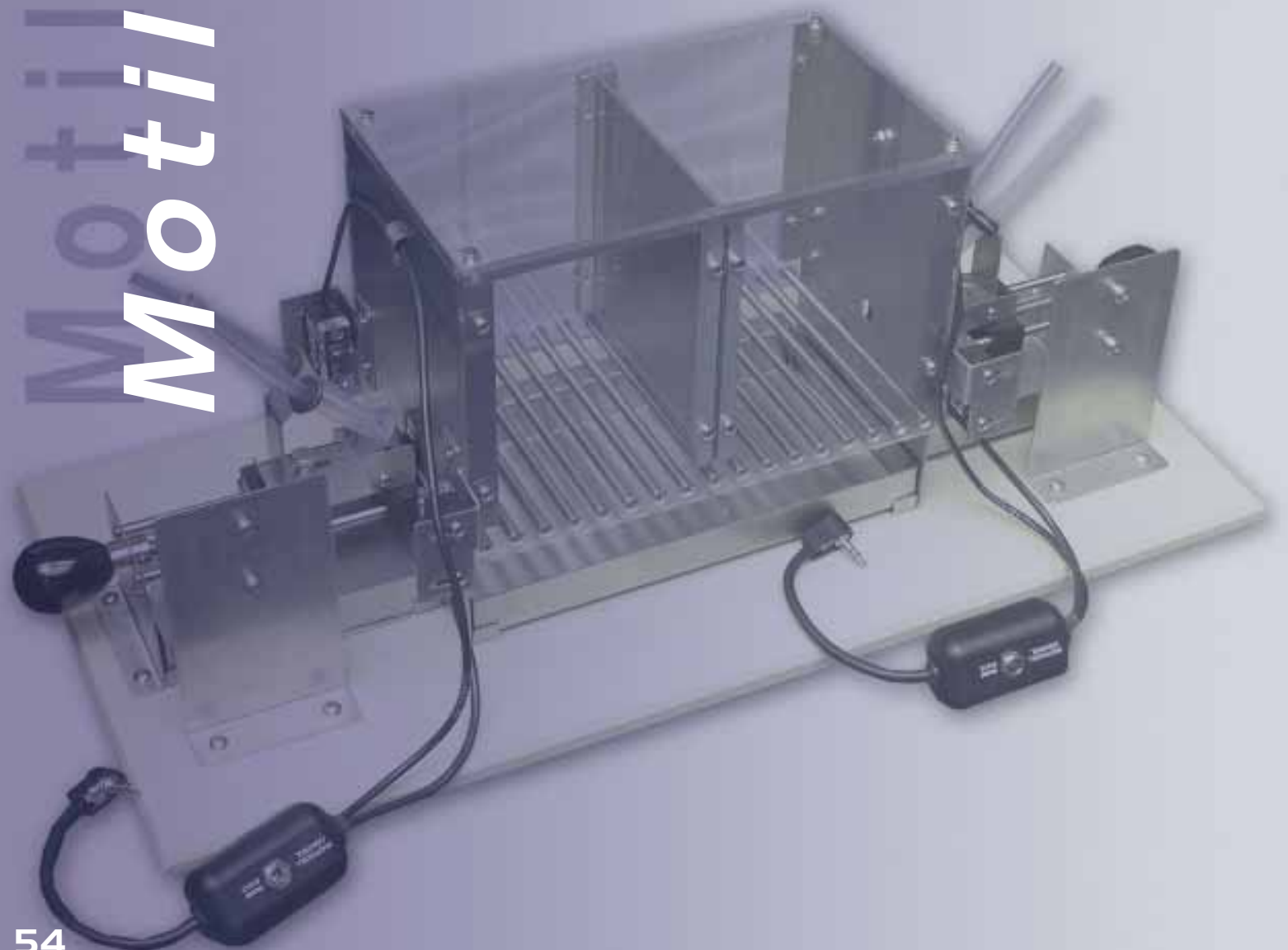



## AUTOMATED MOUSE REACHING CHAMBER MODEL 80870

The automated mouse reaching chamber allows researchers to simultaneously measure motor behavior, cognitive processing and motivation.

**Motor Behavior:** Skilled forepaw reaching behaviors are required to retrieve pellets from the food hopper.

- Divided chamber to test two animals simultaneously.
- The gap between the pellet hopper and chamber discourages "scooping" behavior and encourages pellet grasping.
- Infrared recording accurately quantifies reach attempts as well as latency.
- Use Model 86060 Counter with digital display for reach attempts only.
- Use Model 86060 or 86061 Counters with AWM Software and Interface to log attempts in incremental time bins.
- Reach attempts exceeding the number of pellets removed from the hopper indicates unsuccessful attempts.
- Pellets removed or scooped from the hopper but dropped outside of the chamber into a drop pan indicate pellets grasped but not retrieved.
- Pellets that drop through the grid-floor into the waste pan indicate pellets successfully retrieved but not eaten.



**Cognitive Processing:** Two reaching holes on opposite walls allow researchers to alternate baited and non-baited hoppers within or between trials.

- Walls may be marked for visually cued cognitive tasks.
- Latency measures and non-baited hopper reach attempts are used to assess cognitive deficits.
- Connect to AWM Software Model 86065 and Interface Model 86056 for automated data collection.

**Motivation:** Latency measures from chamber introduction to the first reach attempt indicates motivation to retrieve pellets.



## AUTOMATED MOUSE REACHING CHAMBER (continued)

### Advantages over other chambers:

- Staircase reaching chamber can not assess cognitive functions.
- Trough-type reaching chambers do not discourage "scooping" behavior.
- Staircase and trough-type reaching chambers do not quantify unsuccessful reach attempts.
- Staircase and trough-type reaching chambers do not quantify latency measures.
- A home-cage pellet hopper is available for effortless, time saving and quantifiable training.
- Automated reaching chamber may be combined with other operant accessories.
  - Stimulus light or tone to indicate baited and/or non baited hopper
  - Press bar or nose-poke in combination with pellet feeder to supply hopper with a single reward

### Options:

- **Model 86060** - Activity Counter with Display - to quantify reach attempts
- **Model 86061** - Activity Counter for Computer Interface only - to quantify reach attempts
- **Model 86056** - Computer Interface and Activity Software - to collect data and latency measures
- **Model 88500** - ABET Software & Starter Kit - for operant control and monitoring
- **Model 80875** - Automated Reaching Chamber Home-Cage Training Hoppers



### Technical Specifications:

<b>Overall Dimensions:</b>	19.0" x 9.0" x 7.3"
<b>Chamber Dimensions:</b>	8.0" x 4.4" x 4.6"
<b>Reach Gap:</b>	Fully adjustable from 0.125" to 2.00"
<b>Chamber Material:</b>	End Walls- 0.032" Stainless Steel Side Walls 0.188" Clear Polycarbonate Lid - 0.188" Clear Polycarbonate Hoppers - Delrin with Stainless Steel Walls Pellet Drop Pans - 0.032" Stainless Steel Waste Pan - 0.032" Stainless Steel Grid Rods - Stainless Steel
<b>Photo Detectors:</b>	Two durable industrial grade photo beam pairs



## RODENT MOTILITY STAIRCASE TEST

**Rat Motility StairCase Test Model 80300**

**Mouse Motility StairCase Test Model 80301 (not shown)**

The staircase apparatus provides a simple, efficient and easy way to quantify the testing of skilled paw reaching for both the rat and the mouse. Two food pellets are placed onto each step of two staircases located one on either side of a central plinth. The animals are placed in a box relevant to their size and can reach down either side of a plinth to grasp, lift and retrieve food pellets from the steps of the staircase. The numbers of pellets removed provides a quantifiable measure of the distance and efficiency of reaching skill.

The design allows separate measurements of reaching capacity with the left and right paws, and does not require any constraint or restriction of the contralateral limb to measure performance on the two sides separately. The test is sensitive to unilateral lesions of the striatum, forebrain dopamine systems and sensorimotor cortex, as well as focal ischaemia.

Animals must make a coordinated reach and grasp to retrieve a pellet. They cannot simply scoop up pellets, which can confound the interpretation of results when measuring reaching into tubes. The numbers of pellets removed and the number of pellets knocked down to lower steps provide separate measures of how far the animal can reach, and from how far it can make a coordinated reach, grasp and retrieval of the pellet. For example, striatal lesions have less effect on the actual distance of reaching than on the animal's ability to make a skilled grasp and retrieval.

This test provides an objective quantification of reaching, measured simply in terms of numbers of pellets displaced and retrieved. It does not require observer ratings of numbers of reaching attempts, success or efficiency. The staircase test has been adopted by several groups investigating the effects of unilateral lesions in the basal ganglia and motor systems of the brain because it is sensitive to the effects of drugs and grafts.

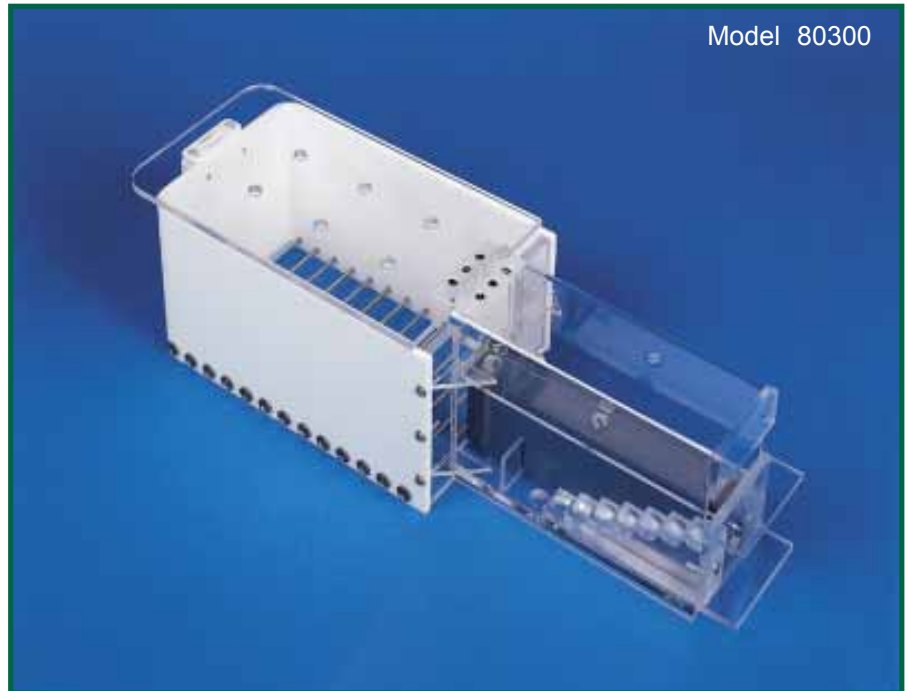



# Monkey CANTAB

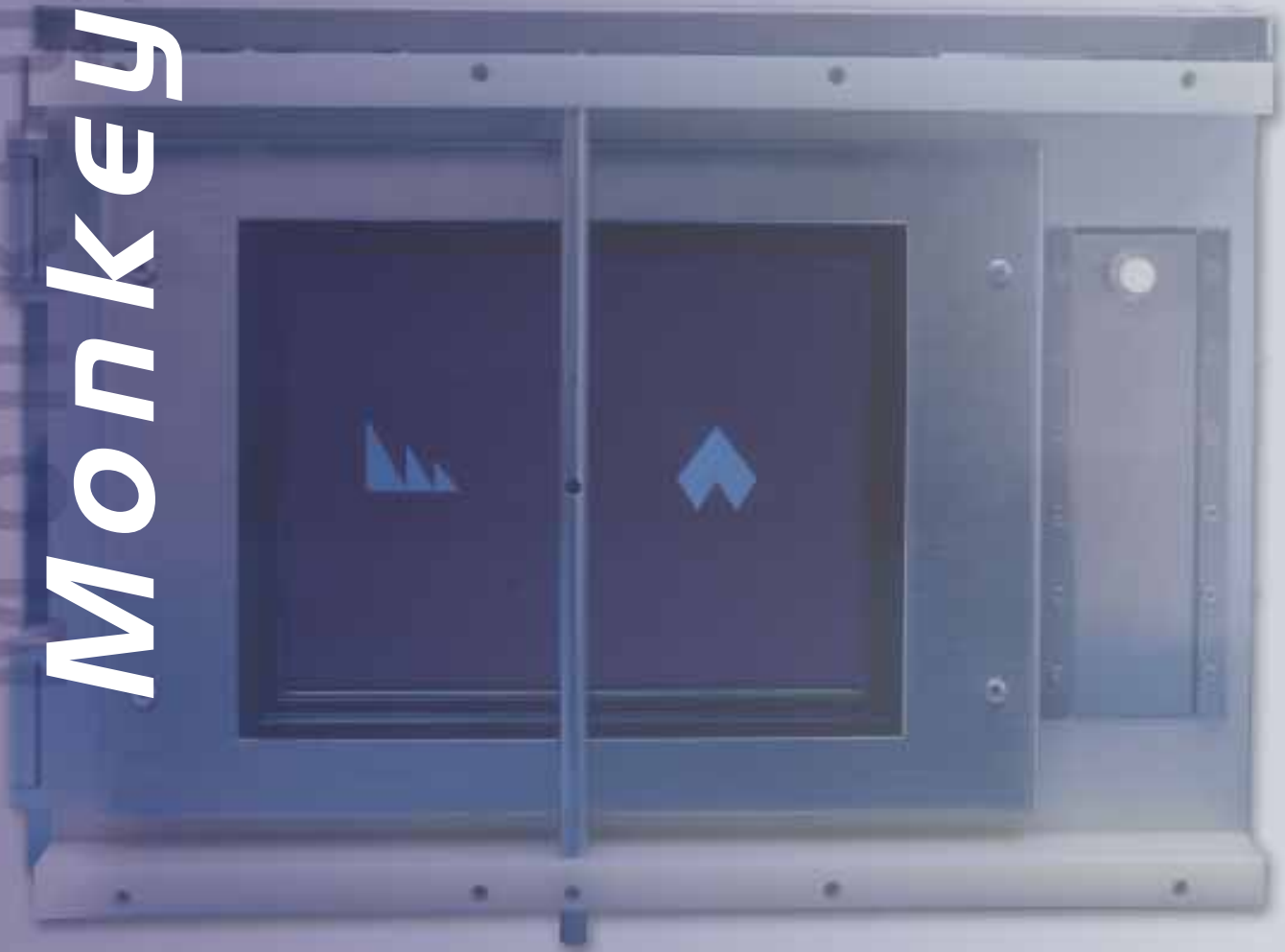



## MONKEY CANTAB

- Primate version of CANTAB – the Cambridge Neuropsychological Test Automated Battery
- Computerized Cognitive Assessment for non-human primates
- Comprises tests from the human batteries, adapted for use with non-human primates
- Facilitates a direct comparison with human data
- Facilitates comparisons with other species, e.g. rodents
- Proved results with both Rhesus monkeys and marmosets
- **Now available – New Windows version of the software, allowing even more flexibility to change the tests to your own design**



Monkey CANTAB is the primate version of CANTAB. Alterations from the human tests have been restricted to the absolute minimum consistent with the ability of the animals to learn the tasks. This facilitates a direct comparison with results from the human batteries. The excellent sensitivity of the tests and the direct comparison with human results makes Monkey CANTAB ideal for:

- the characterization of the functional organization of the brain
- the development of new and improved animal models of brain disorders
- the early identification of progressive disorders, whether endogenous or as a result of environment

## The Tests:

Monkey CANTAB comprises a battery of tests performed via a touch screen. Batteries can be configured for either pellet or liquid reward.

The battery is comprised of the following tests:

- Reinforcement Familiarization
- Training Program
- Intra/Extra-Dimensional Set-Shift and Visual Discrimination (ID/ED)
- Delayed Match / Non-Match to Sample
- Spatial Working Memory
- Five-Choice Serial Reaction-Time Task
- Paired Associates Learning
- Schedules – FR, FI, VR, VI, Progressive Ratio

## The Apparatus:

**Robust aluminum testing station** incorporating a LCD monitor and toughened splash-proof IR touch-screen System allows for testing at the home cage.

### Remote control and monitoring:

A 10m cable connects the test unit to the multimedia control unit. Call-up window allows you to see what the Monkey does and also shows where the monkey is pointing.

System can also run Whisker Multimedia software, which allows you to program your own schedules.

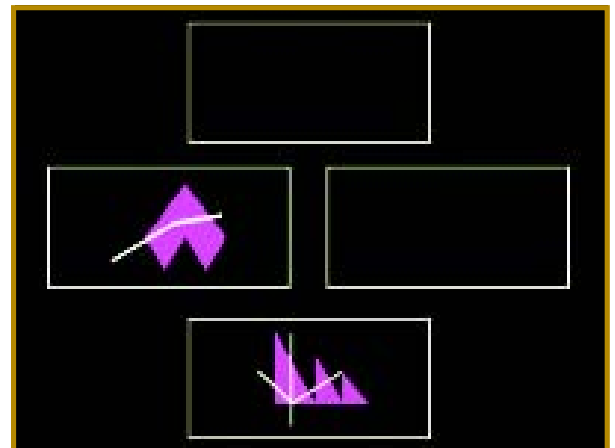

## MONKEY CANTAB FOR WINDOWS - HARDWARE

### The Multimedia Control System

The Multimedia control hardware is used to control the Monkey CANTAB tests units and other multimedia hardware (which includes the Rat and Bird Touchscreen test chambers).

Multimedia control consists of an industrial grade multimedia PC (containing audio, graphic, and touch array cards) and a Multimedia Controller Unit, incorporating a 24V DC power supply to drive chambers. There are two multimedia control systems available- a unit to drive up to two touchscreen units or a unit to drive up to four touchscreen units.

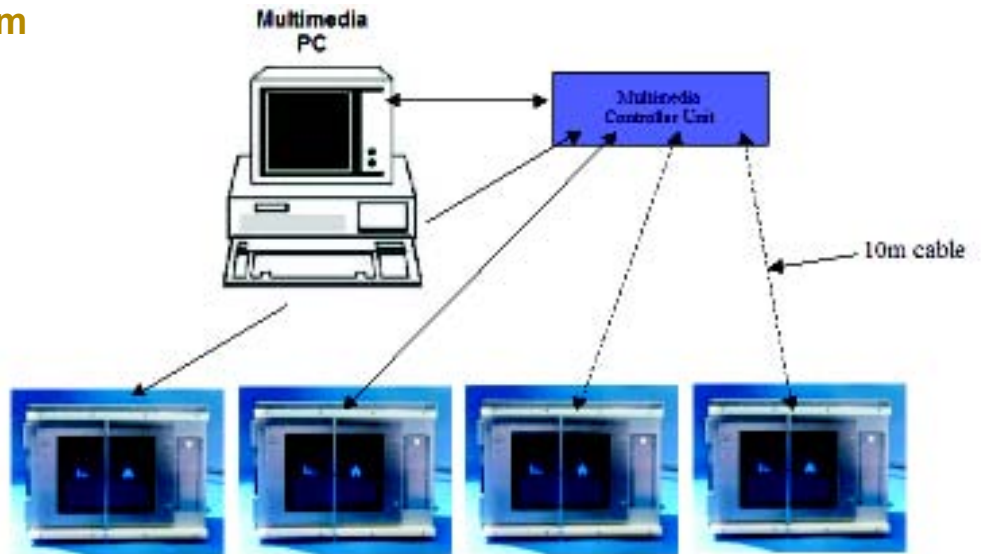

### The Monkey CANTAB Test units

**Testing Station** comprising 12.1" toughened splashproof IR touch-screen with LCD monitor, mounted in a robust aluminum enclosure (520mm width x 375mm height x 310mm depth, wt 22.5kg). There are lockable side panels to access the feeders. A 10m cable connects the test station to the multimedia control system.

#### Options:

**Touch Screen Testing Station – Pellet:** This test station has been favored by users working with Rhesus monkeys but can be used with any non-human primate responding to a 190 mg pellet (45 mg on request). Features of this unit include the touch screen panel encased in a heavy-duty metal frame and metal enclosure with a fixed response lever, pellet dispenser and receptacle, 2 sound stimuli and house/session light. Liquid reward from a peristaltic pump to a licker tube may be added as an option to this unit.

**Touch Screen Testing Station – Liquid:** This test station has been favored by users working with Marmoset monkeys but can be used with any non-human primate responding to a liquid reward delivered from a peristaltic pump. Two lick tube variations are available. The standard (pictured above) uses a straight vertical tube with the sipper tip recessed behind an access port. An optional bent lick tube that protrudes from the tube pictured is also available. Features of this unit include the touch screen panel, a fixed response lever, 2 sound stimuli and a house/session light.

**Portable Cart/Trolley Accessory:** The testing stations listed above may be hung on the outside of the cage or used with an optional cart that can be rolled up to the cage. A variable height unit is possible. Please provide cage specifications to see a cart system is available for your lab.



*Picture shows the set-up for marmosets with a licker placed across the screen. (Alternatively a remote licker can be attached.)*

*Pictured below are the remote power supply, LCD display and keyboard*





## MONKEY CANTAB FOR WINDOWS – SOFTWARE

The Monkey CANTAB for Windows software runs on Windows 2000 or XP. It is easier to set-up and more flexible than the older DOS software.

To access the results you will also need an ODBC-compatible database. The supplied database is in Microsoft Access format. You need Microsoft Access (97 or higher) to use this database.

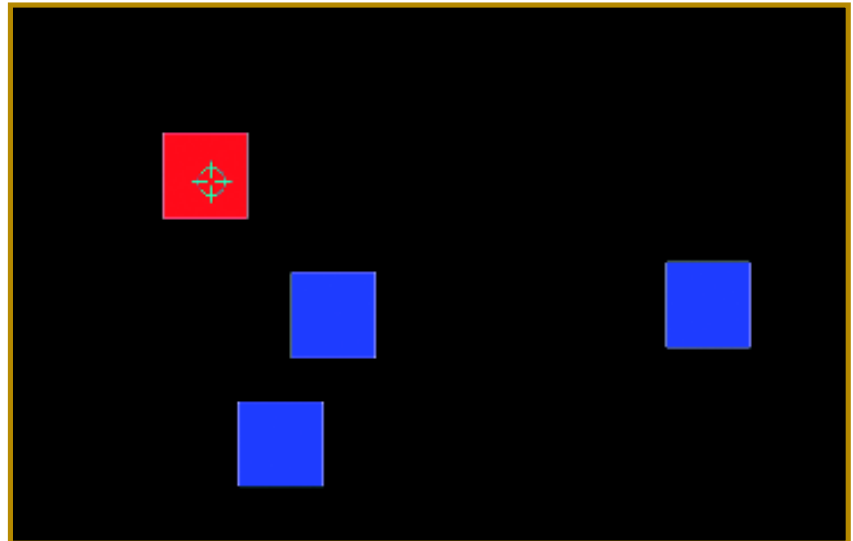

Spatial Working Memory Test Screen

## The Tests

The tests available are:

- Reinforcement Familiarisation with optional signal-reward association
- Training Program - development of accurate responding to the screen
- Spatial Working Memory - analogous to the Olton Maze
- Delayed Matching/Non-Matching to Sample with trial-unique stimuli
- Simple and Compound Visual Discriminations, Reversals, Intra- Dimensional and Extra-Dimensional Set-Shifting, analogous to the Wisconsin Card Sort Test.
- Multiple-Choice Serial Reaction-Time task modelled after Leonard
- Schedules - FR, FI, VR, VI, Progressive Ratio
- Paired-Associate Conditional Learning of pattern-location associations

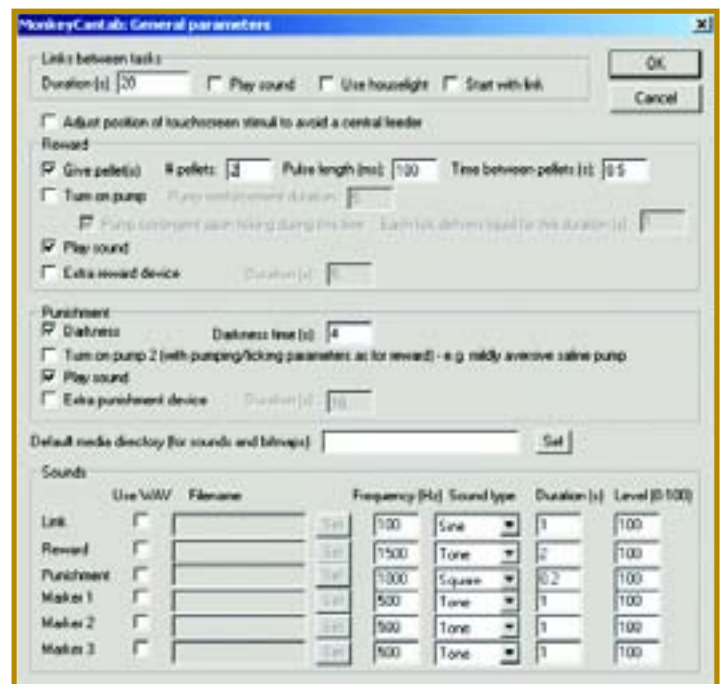



**Notes:**

## Ordering and Contact Information

### LIC Worldwide Headquarters:

Call: 765.423.1505  
Toll-Free 1.800.428.7545 (USA only)  
Fax: 765.423.4111  
E-mail: sales@lafayetteinstrument.com  
lic@lafayetteinstrument.com  
Write: Lafayette Instrument Company  
P.O. Box 5729  
Lafayette, IN 47903 USA  
Ship: 3700 Sagamore Parkway N.  
Lafayette, IN 47904 USA

### Campden Instruments LTD. A Lafayette Instrument Company European Headquarters:

Call: +44 1509 817700  
Fax: +44 1509 817701  
E-mail: EUsales@lafayetteinstrument.com  
Write/Ship: Campden Instruments  
4 Park Road, Sibley,  
Loughborough. LE12 7TJ. UK

Please include the following information on all orders: (Phoned orders must be followed by a hard copy.)

- 1) Complete billing and shipping addresses
- 2) Name and department of end user
- 3) Model number and description of desired item(s)
- 4) Quantity of each item desired
- 5) Purchase order number or method of payment
- 6) Telephone number

### DOMESTIC TERMS

There is a \$50 minimum order. Open accounts can be extended to most recognized educational institutions, hospitals and government agencies. Net amount due 30 days from the date of shipment. Enclose payment with the order; charge with VISA, MasterCard, American Express; or pay COD. We must have a hard copy of your order by mail or fax. Students, individuals and private companies may call for a credit application.

### INTERNATIONAL PAYMENT INFORMATION

There is a \$50 minimum order. Payment must be made in advance by: draft drawn on a major US bank; wire transfer to our account; charge with VISA, MasterCard, American Express; or confirmed irrevocable letter of credit. Proforma invoices will be provided upon request.

### EXPORTS

If ordering equipment for use outside the USA, please specify the country of ultimate destination, as well as the power requirements (110V/60Hz or 220V/50Hz). Model numbers for 220V/50Hz will have a "\*\*C" suffix.

### QUOTATIONS

Quotations are supplied on an as-requested basis. Written quotations will include the price of goods, plus estimated shipping and handling if requested. Quotations are good for 30 days; following that time, prices are subject to change. In such a case, please ask us to requote your order.

As our catalogs are referred to by our customers for many months, we reserve the right to change prices without notice. Prices may vary between our ads and our catalogs. Product description, typographic, pricing and photographic errors are unintentional and subject to correction. Products are available in both 110V/60Hz or 220V/50Hz. The material presented in this publication is copyright-protected and may not be reproduced in any form, by any method, for any purpose without the prior written consent of Lafayette Instrument Company. © 2001 by Lafayette Instrument Company

### EXCHANGES and REFUNDS

Unaccepted merchandise may be returned for credit *only* if we have been consulted and have issued prior authorization. The merchandise should be packed well, insured for the full value and returned along with a cover letter explaining the reason for return. Merchandise may be returned prepaid within thirty (30) days after receipt of the item and in the original shipping carton. Collect shipments will not be accepted. Unit must be returned in saleable condition, and credit is subject to inspection of the merchandise. Customer may be assessed a restocking fee of up to 20%.

### RETURNS

**Equipment may not be returned without first receiving a Return Goods Authorization Number (RGA).**

When returning equipment for service, please call Lafayette Instrument to receive a RGA number. Your RGA number will be good for 30 days. Address the shipment to: Lafayette Instrument Company, 3700 Sagamore Parkway North, Lafayette, IN 47904, USA. Shipments cannot be received at the PO Box. The items should be packed well, insured for full value, and returned along with a cover letter explaining the malfunction. Please also state the name of the Lafayette Instrument representative authorizing the return. An estimate of repair will be given prior to completion **ONLY** if requested in your enclosed cover letter. We must have a hard copy of your purchase order by mail or fax, or repair work cannot commence.

### WARRANTY

Lafayette Instrument guarantees its equipment against all defects in materials and workmanship to the ORIGINAL PURCHASER for a period of one (1) year from the date of shipment, unless otherwise stated. During this period, Lafayette Instrument will repair or replace, at its option, any equipment found to be defective in materials or workmanship. If a problem arises, please contact our office for prior authorization before returning the item. This warranty does not extend to damaged equipment resulting from alteration, misuse, negligence or abuse, normal wear or accident. In no event shall Lafayette Instrument be liable for incidental or consequential damages. There are no implied warranties or merchantability of fitness for a particular use, or of any other nature. Warranty period for repairs or used equipment purchased from Lafayette Instrument is 90 days.

### DAMAGED GOODS

**Damaged equipment should not be returned to Lafayette Instrument prior to thorough inspection.**

When a shipment arrives damaged, note damage on delivery bill and have the driver sign it to acknowledge the damage. Contact the delivery service, and they will file an insurance claim. When damage is not detected at the time of delivery, contact the carrier and request an inspection within 10 days of the original delivery. Please call the Lafayette Instrument Customer Service Department for a return authorization for repair or replacement of the damaged merchandise.

### EXPORT LICENSE

The U.S. Department of Commerce requires an export license for any polygraph system shipment with an **ULTIMATE** destination other than: **Australia, Japan, New Zealand or any NATO Member Countries excluding the Czech Republic, Hungary and Poland.** It is against **U.S. law** to ship a Polygraph system to any other country without an export license. If the ultimate destination is not one of the above listed countries, contact us for the required license application forms.

# ***ANIMAL SCIENCES***

**Instrumentation & Software For Animal Research Professionals**

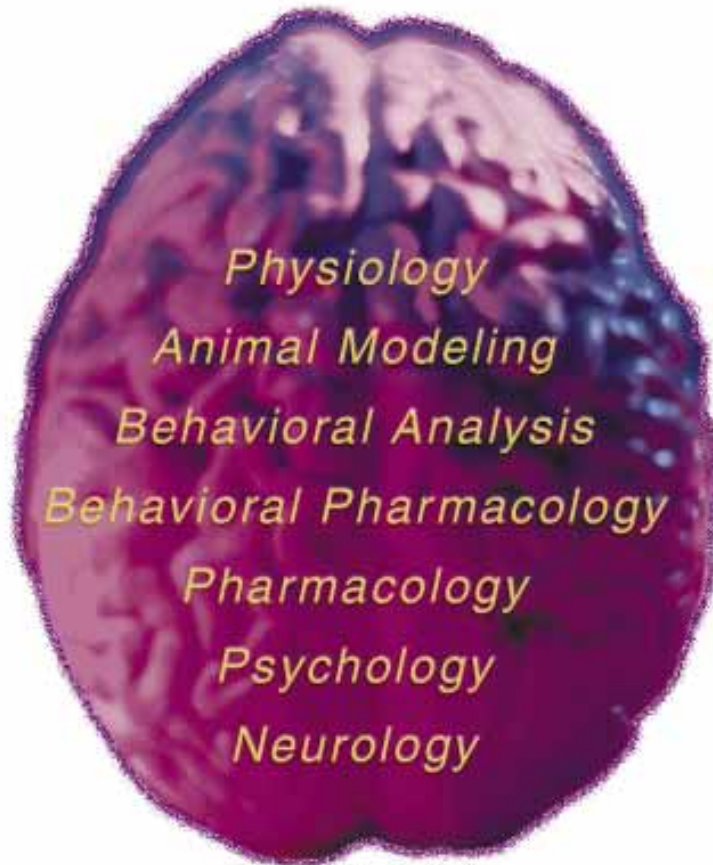

3700 Sagamore Parkway North  
P.O. Box 5729 • Lafayette, IN 47903 USA  
**Tel:** 765.423.1505 • 800.428.7545  
**Fax:** 765.423.4111  
**E-mail:** [sales@lafayetteinstrument.com](mailto:sales@lafayetteinstrument.com)  
[www.lafayetteinstrument.com](http://www.lafayetteinstrument.com)

***Lafayette Instrument Europe***  
*Incorporating Campden Instruments Ltd.*

4 Park Road, Sileby,  
Loughborough. LE12 7TJ. UK  
**Tel:** 01509817700  
**Fax:** 01509 817701  
**E-mail:** [EUsales@lafayetteinstrument.com](mailto:EUsales@lafayetteinstrument.com)